

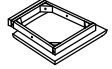
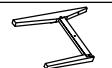

ASSEMBLY INSTRUCTIONS

30030/30021 CHAIR

PARST LIST

No.	DESCRIPTION	SKETCH	Q'TY
A	BACK		1PC
B	CUSHION SEAT		1PC
C	RIGHT SIDE LEG FRAME		1PC
D	RIGHT SIDE LEG FRAME		1PC

HARDWARE LIST

NO.	DESCRIPTION	SKETCH	Q'TY
1	ALLEN KEY 4MM		1PC
2	SPRING WASHER Ø1/4"		6PCS
3	FLAT WASHER Ø1/4"X22MM		6PCS
4	BOLT Ø1/4"*82MM		4PCS
5	BOLT Ø1/4"*38MM		2PCS
6	BOLT Ø1/4"*50MM		2PCS
7	NUTS		2PCS
8	WOOD SCREW #8"*50MM		2PCS

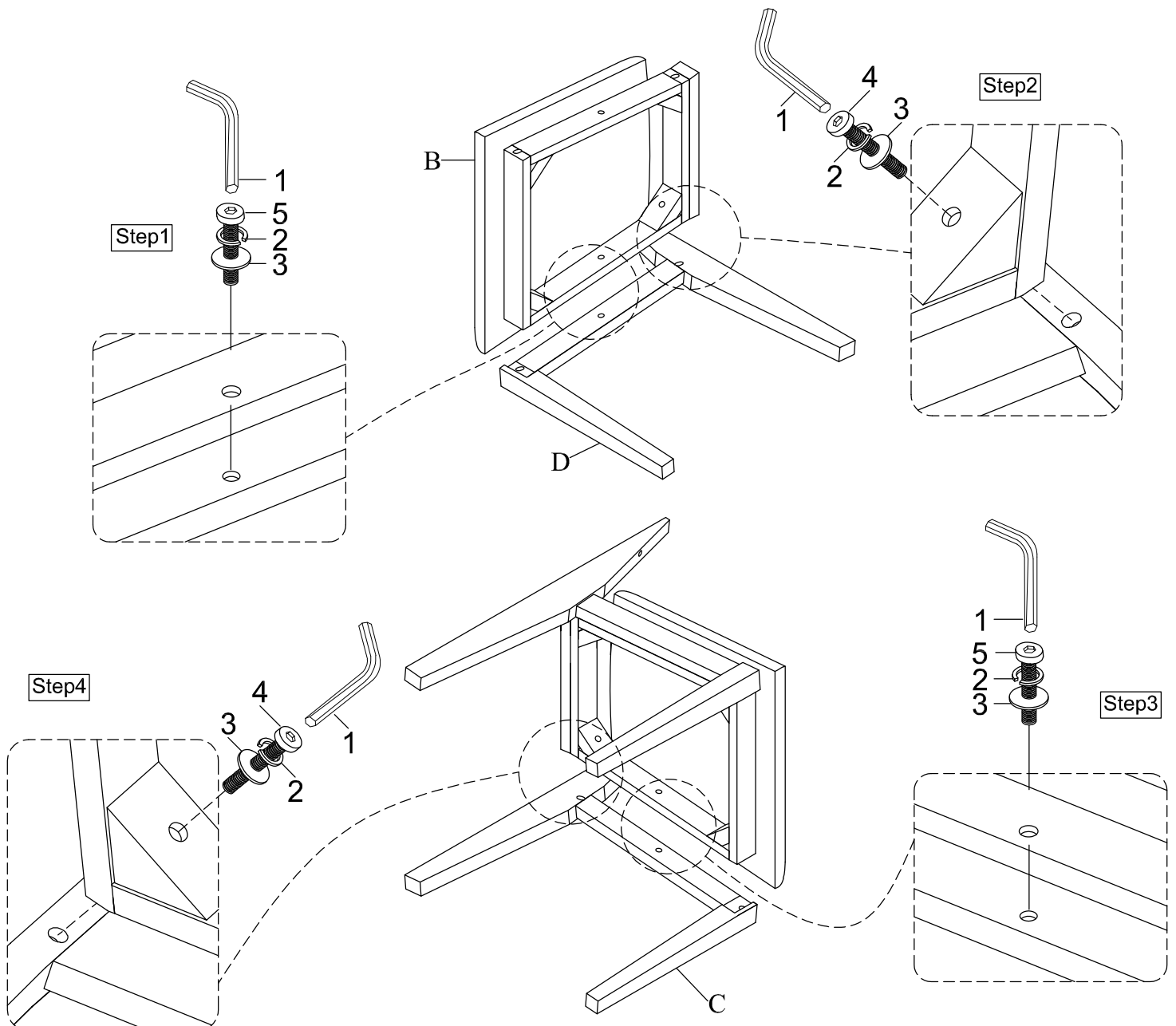

ASSEMBLY INSTRUCTIONS

30030/30021 CHAIR

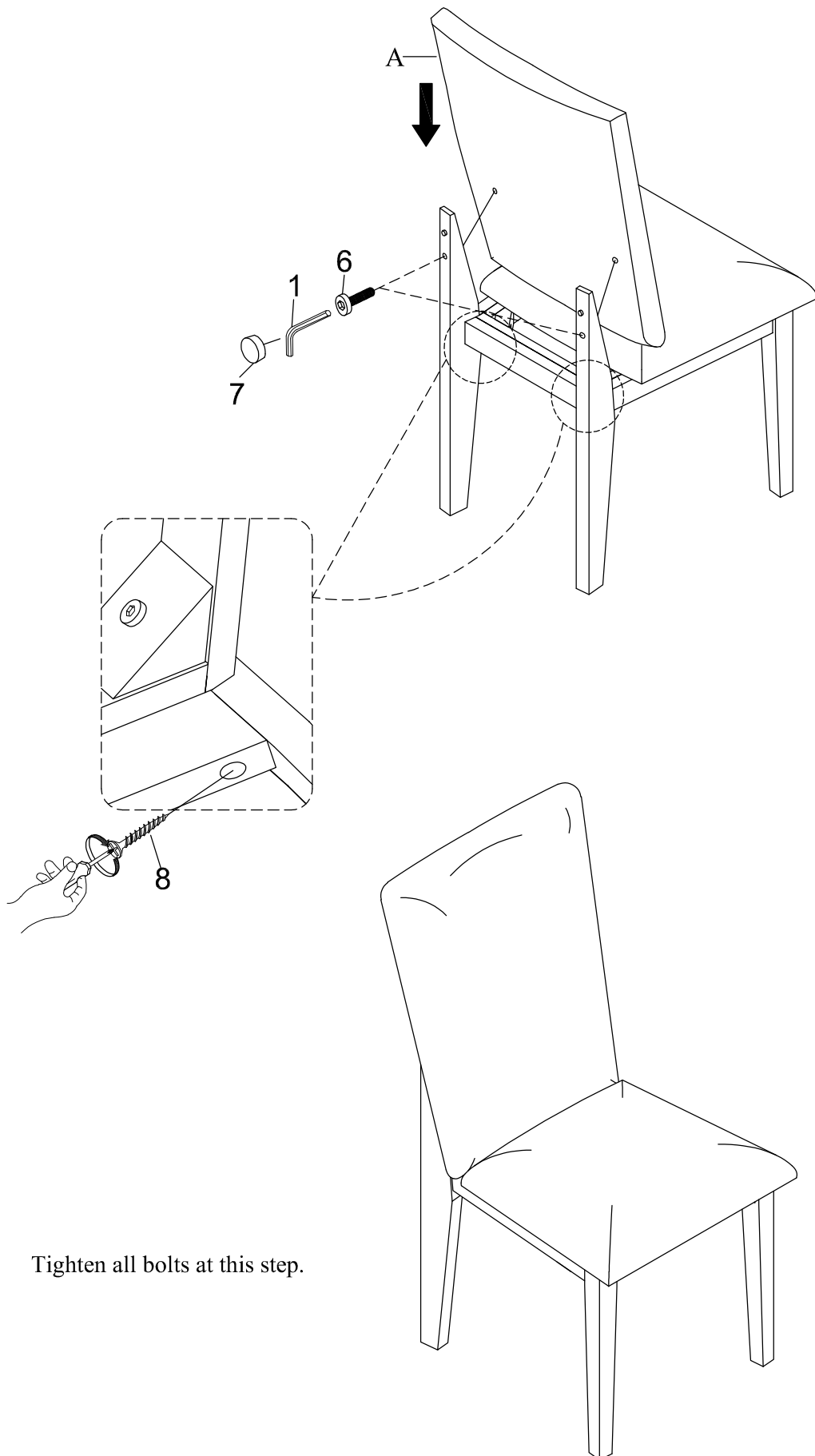

Tighten all bolts at this step.