

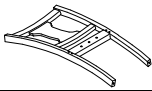







# ASSEMBLY INSTRUCTIONS

## 30040-C SIDE CHAIR

### PARST LIST

No.	DESCRIPTION	SKETCH	Q'TY
A	CHAIR BACK		1PC
B	CUSHION SEAT		1PC
C	FRONT LEG		2PCS

### HARDWARE LIST

NO.	DESCRIPTION	SKETCH	Q'TY
1	ALLEN KEY 4MM		1PC
2	SPRING WASHER Ø1/4"		6PCS
3	FLAT WASHER Ø1/4"X19MM		6PCS
4	BOLT Ø1/4"*82MM		4PCS
5	BOLT Ø1/4"*45MM		6PCS
6	WOOD DOWELS		1PC

### Step:1

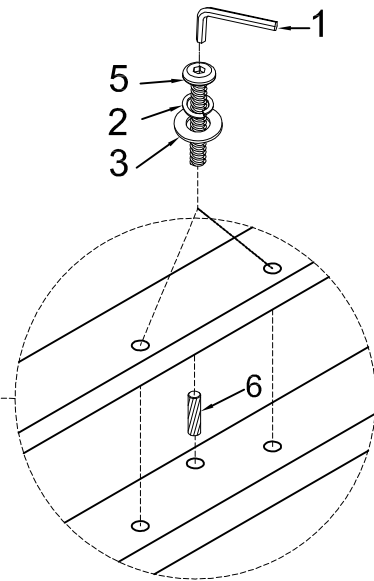
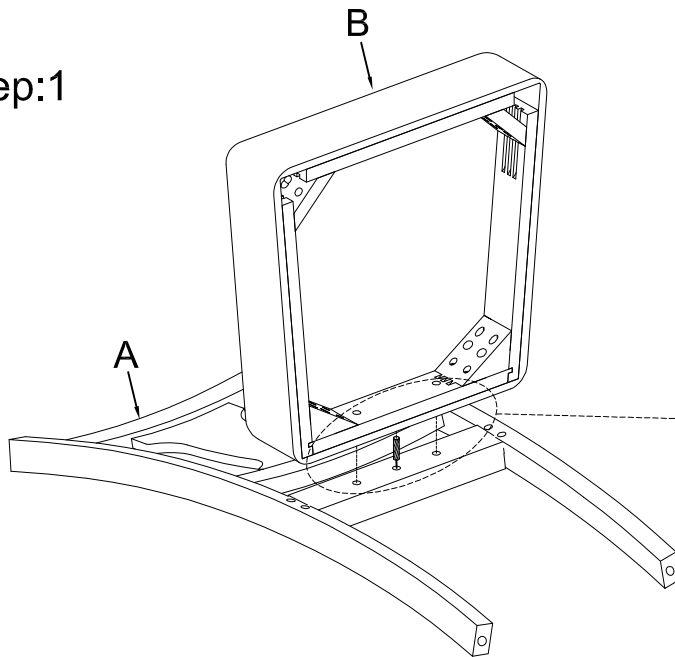

### Step:2

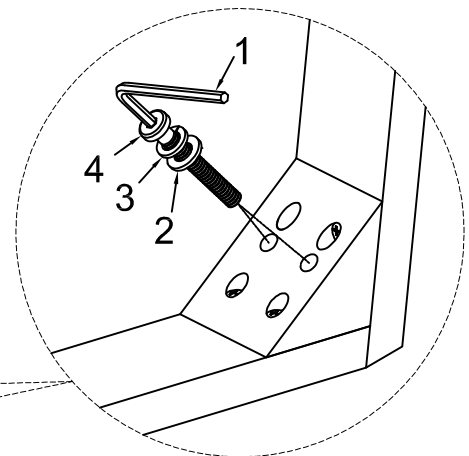
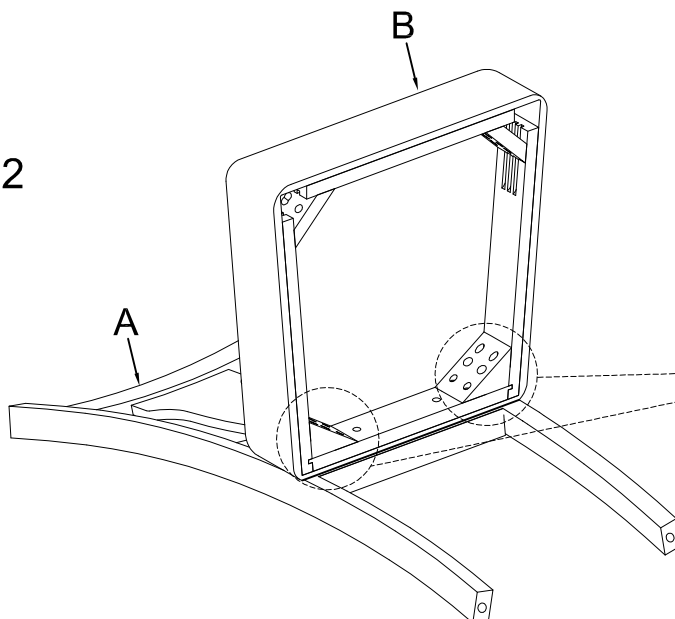

# ASSEMBLY INSTRUCTIONS

## 30040-C SIDE CHAIR

Step:3

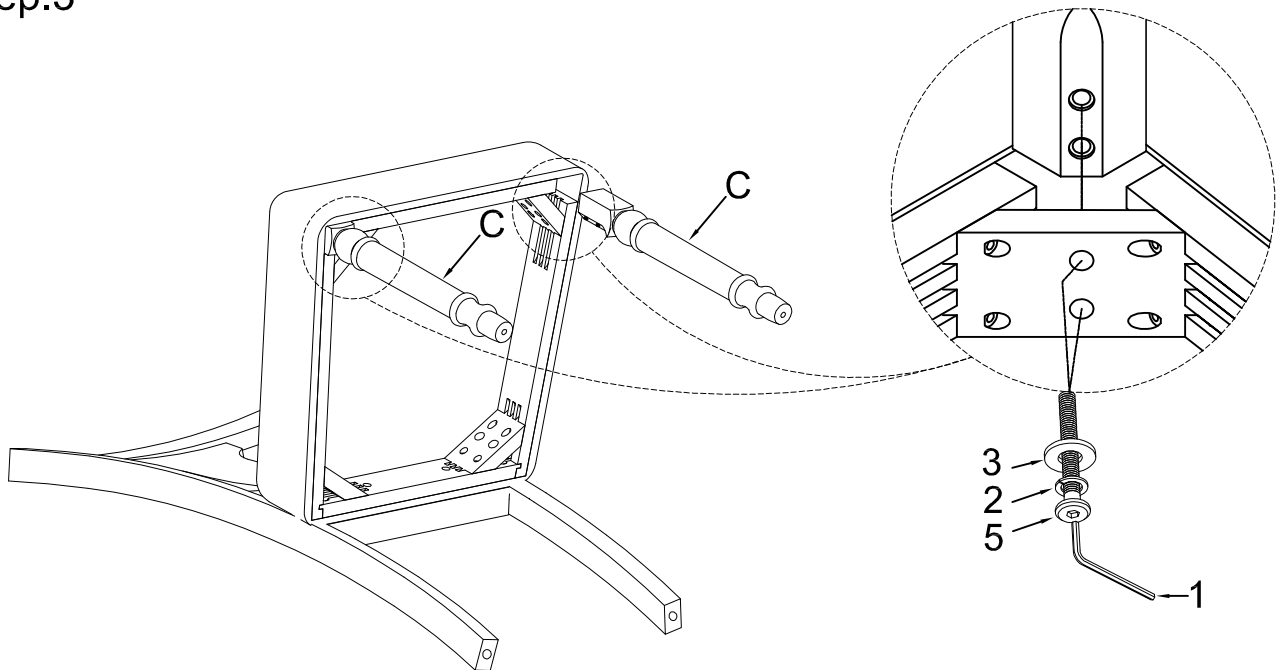

Tighten all bolts at this step.

