

ASSEMBLY INSTRUCTIONS

30044 TABLE

PARST LIST

| No. | DESCRIPTION | SKETCH | Q'TY |
|-----|-----------------------|--------|------|
| A | TOP | | 1PC |
| B | SIDE PANEL+BACK PANEL | | 1SET |
| C | LEFT BACK LEG | | 1PC |
| D | RIGHT BACK LEG | | 1PC |
| E | LEFT FRONT LEG | | 1PC |
| F | RIGHT FRONT LEG | | 1PC |
| G | CENTER STRETCHER | | 1PC |
| H | BACK STRETCHER | | 1PC |
| I | SHELF | | 2PC |
| J | BOTTOM PANEL | | 1PC |

HARDWARE LIST

| NO. | DESCRIPTION | SKETCH | Q'TY |
|-----|------------------------|--------|-------|
| 1 | ALLEN KEY 4MM | | 1PC |
| 2 | BOLT Ø1/4"*57MM | | 8PCS |
| 3 | BOLT Ø1/4"*35MM | | 11PCS |
| 4 | SPRING WASHER Ø1/4" | | 19PCS |
| 5 | FLAT WASHER Ø1/4"X19MM | | 19PCS |
| 6 | SCREW 45MM | | 3PCS |
| 7 | SHELF PIN | | 8PCS |

Step:1

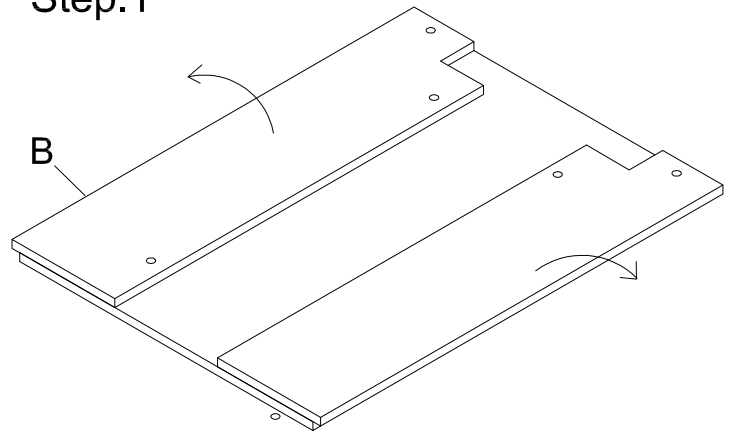

Step:2

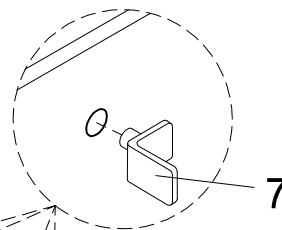

Step:3

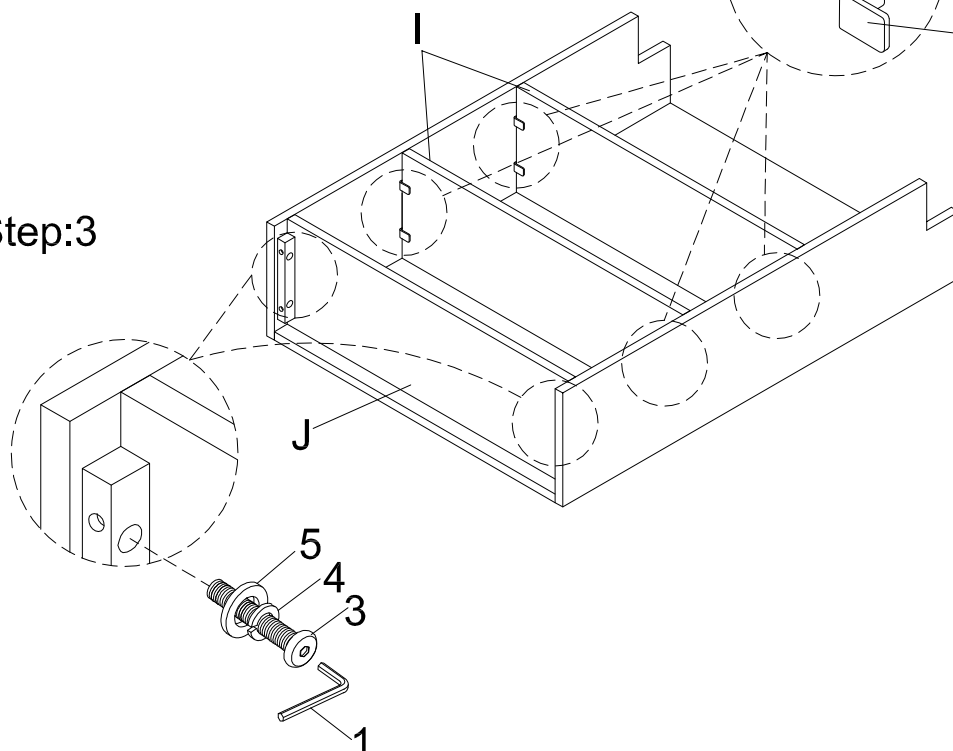

ASSEMBLY INSTRUCTIONS

30044 TABLE

Step:4

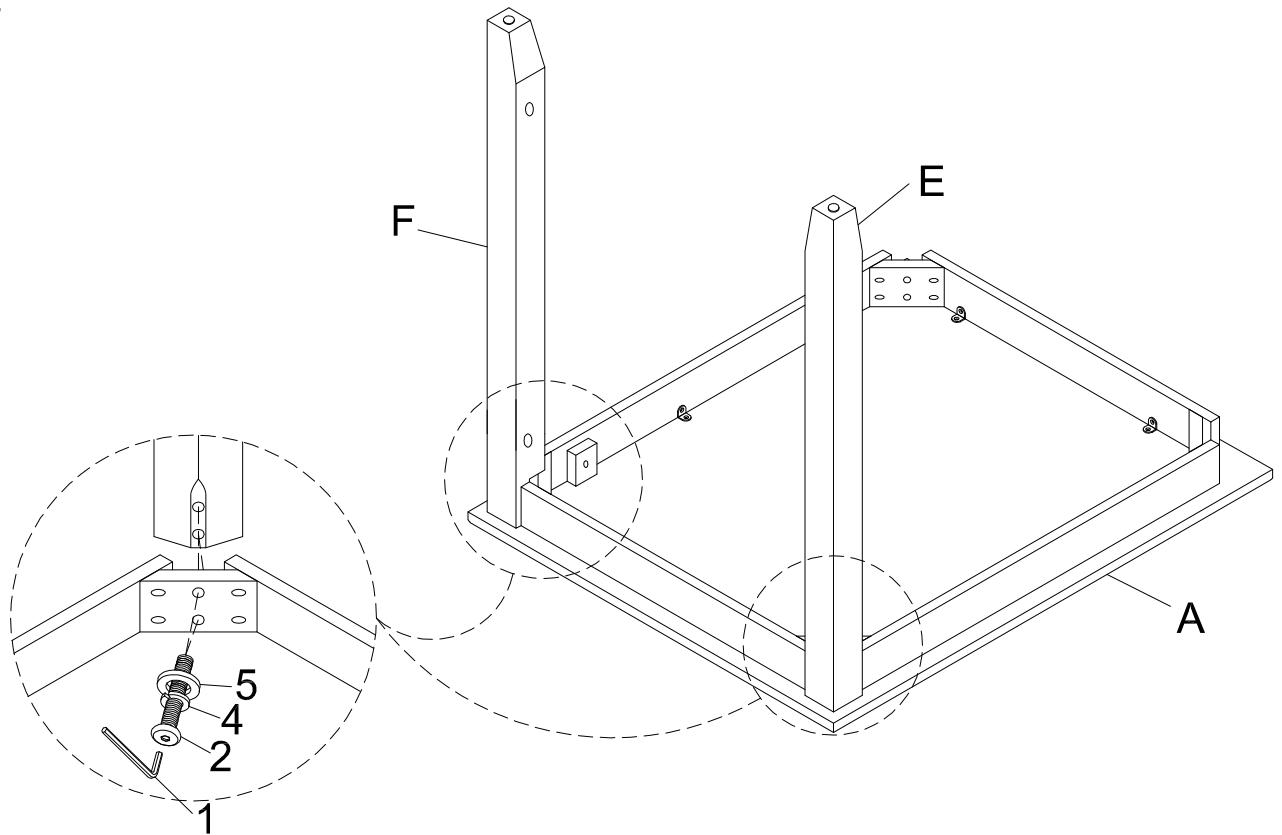

Step:5

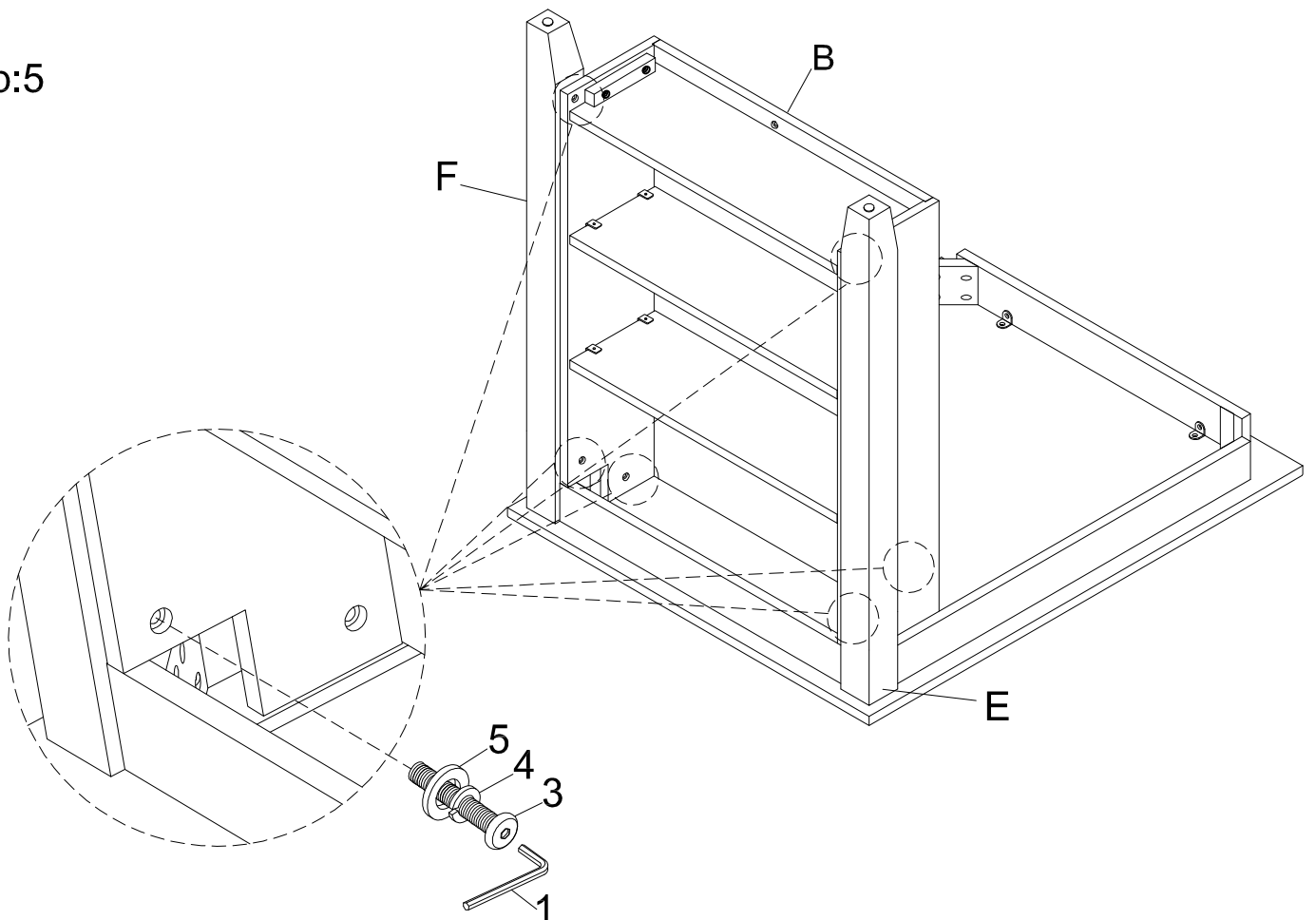

ASSEMBLY INSTRUCTIONS

30044 TABLE

Step:6

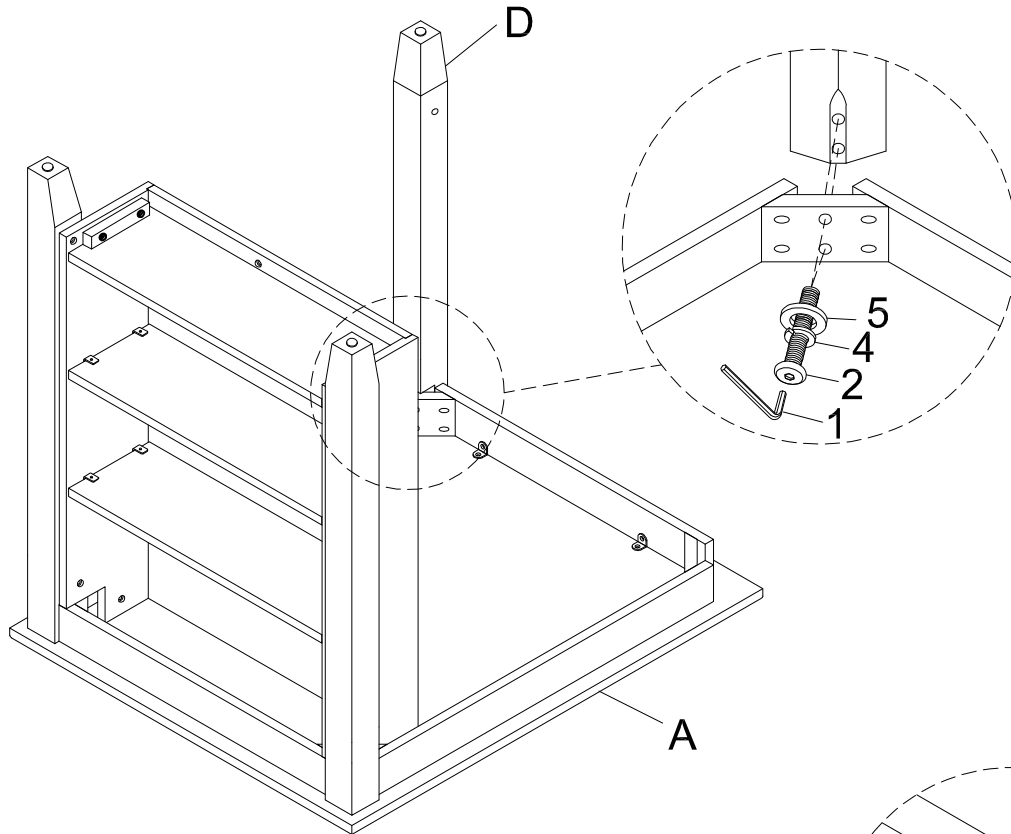

Step:6

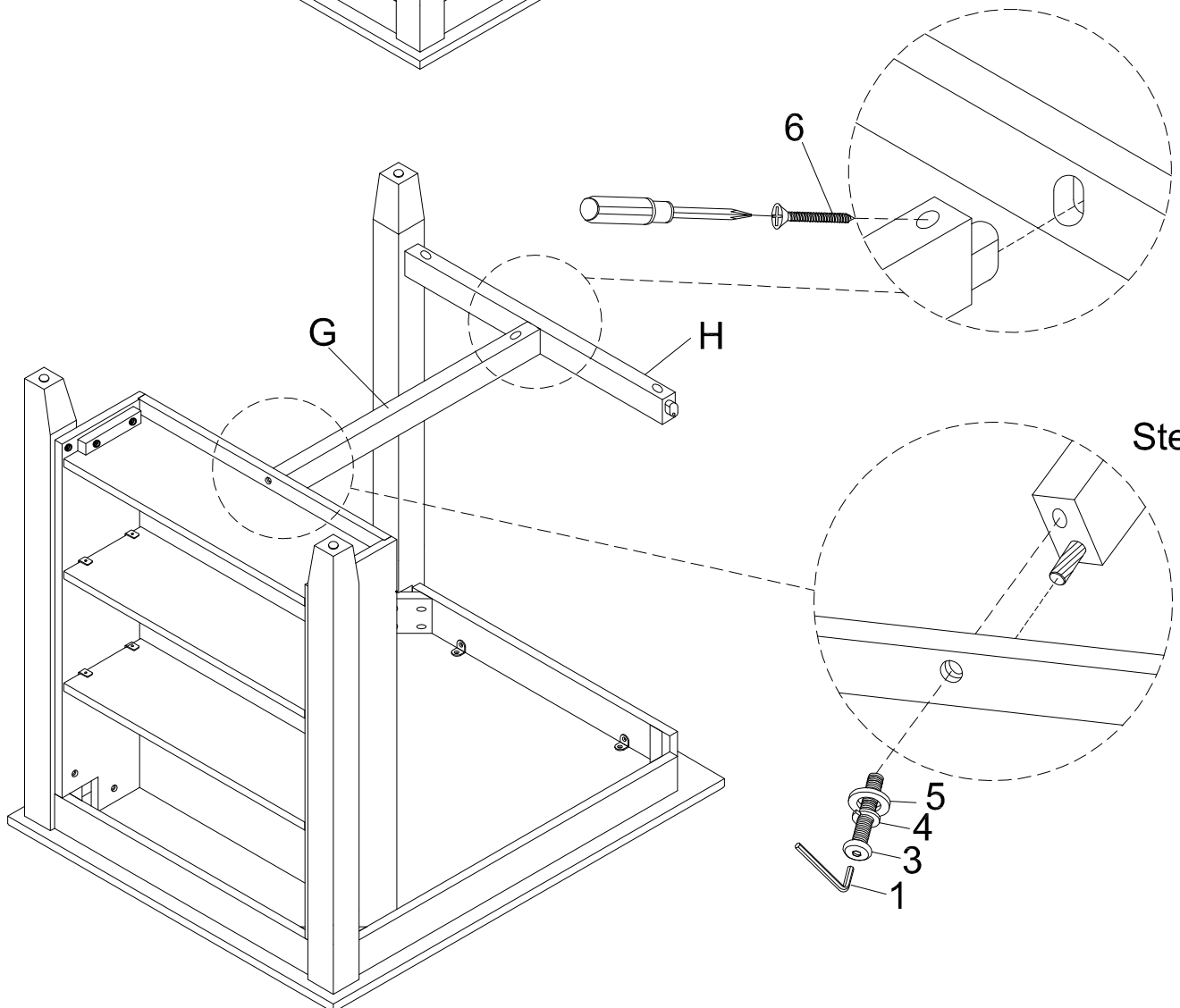

Step:7

ASSEMBLY INSTRUCTIONS



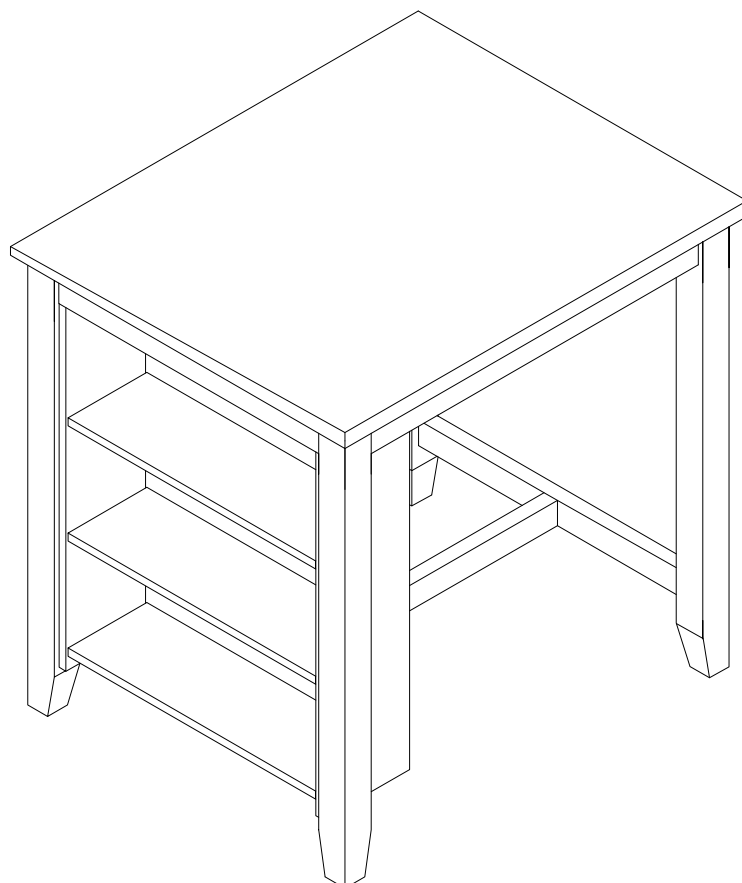
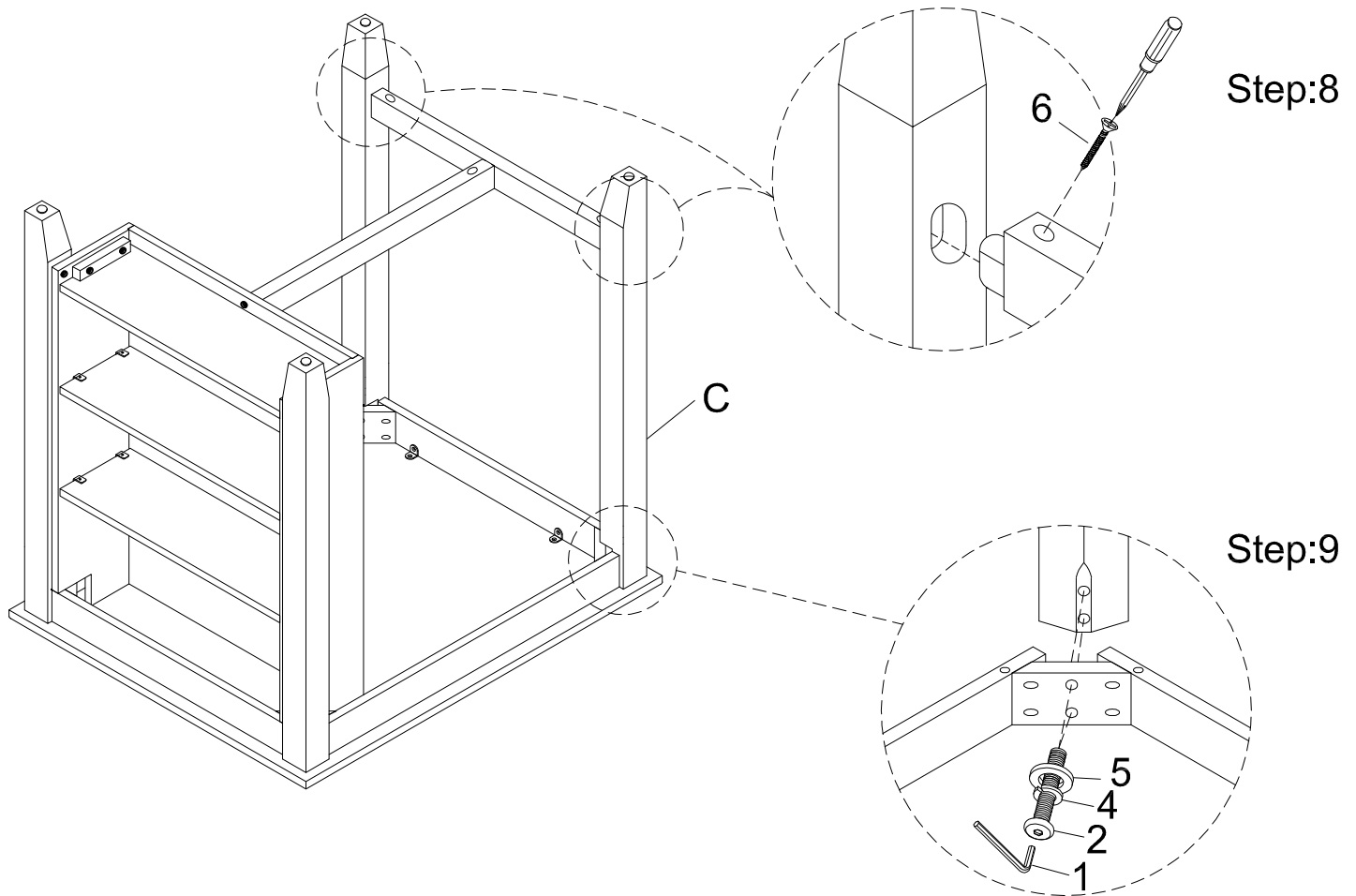

30044 TABLE







ASSEMBLY INSTRUCTIONS

30044 STOOL

PARST LIST

| No. | DESCRIPTION | SKETCH | Q'TY |
|-----|------------------------------|---|------|
| A | STOOL SEAT FARM WITH CUSHION |  | 2PCS |
| B | LEFT STOOL LEGS |  | 4PCS |
| C | RIGHT STOOL LEGS |  | 4PCS |
| D | STOOL FRONT & BACK STRETCHER |  | 4PCS |
| E | STOOL SIDE STRETCHER |  | 4PCS |

HARDWARE LIST

| NO. | DESCRIPTION | SKETCH | Q'TY |
|-----|------------------------|---|-------|
| 1 | ALLEN KEY 4MM |  | 1PC |
| 2 | BOLT Ø1/4"*50MM |  | 8PCS |
| 3 | SPRING WASHER Ø1/4" |  | 8PCS |
| 4 | FLAT WASHER Ø1/4"X19MM |  | 8PCS |
| 5 | SCREW 45MM |  | 16PCS |

Step:1

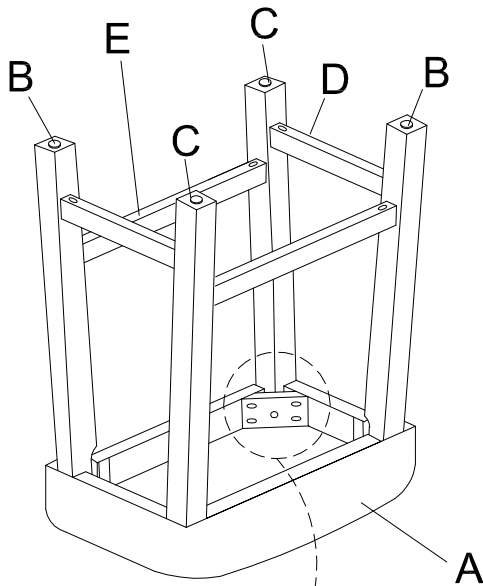

Step:2

