

# ASSEMBLY INSTRUCTION

ITEM# 83123/4/5-RC  
83123/4/5-L  
83123/4/5-LC

Please allow at least 24 hours for the cushions to recover to its natural state after removing from the package.

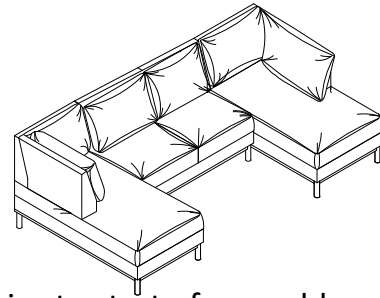

## ASSEMBLY TIPS:











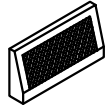
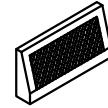
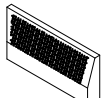
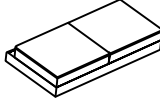
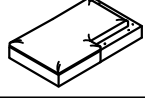

1. Remove hardware from box and sort by size.
2. Please check to see that all hardware and parts are present prior to start of assembly.
3. Please follow attached instructions in the same sequence as numbered to assure fast & easy assembly.

## WARNING!

1. Don't attempt to repair or modify parts that are broken or defective. Please contact the store immediately.
2. This product is for home use only and not intended for commercial establishments.

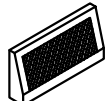
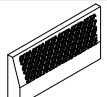
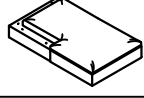
### PARTS LIST OF 83125-RC

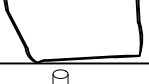
### PARTS LIST OF 83125-L

A	CHAISE BACK		x1	G	LOVE SEAT BACK		x2
B	RIGHT ARM		x1	H	LOVE SEAT		x1
C	CHAISE SEAT		x1	I	BACK CUSHION		x2
D	BACK CUSHION		x1	J	LEG		x4
E	BACK CUSHION		x1	Q	IRON BOND PLATE		x4
F	LEG		x4				
Q	IRON BOND PLATE		x4				
<b>PARTS LIST OF 83125-LC</b>							
K	CHAISE BACK		x1				
L	LEFT ARM		x1				
M	CHAISE SEAT		x1				
N	BACK CUSHION		x1				
O	BACK CUSHION		x1				
P	LEG		x4				
Q	IRON BOND PLATE		x4				

# ASSEMBLY INSTRUCTION

Open up Velcro of Non-Woven Fabric cover on the bottom of the frame to remove  
Please allow at least 24 hours for the cushions to recover to its natural state after removing from the package.

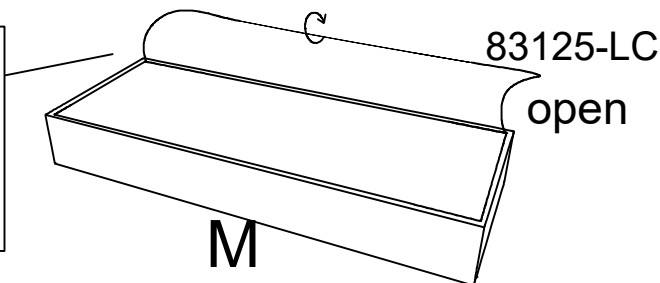
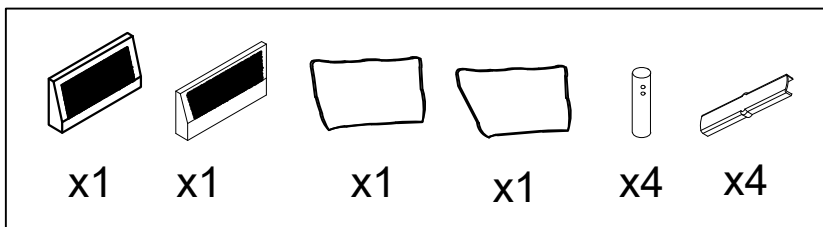
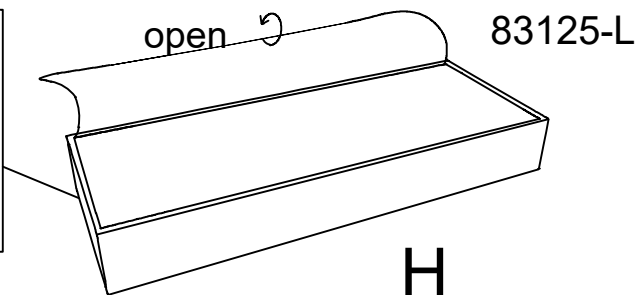
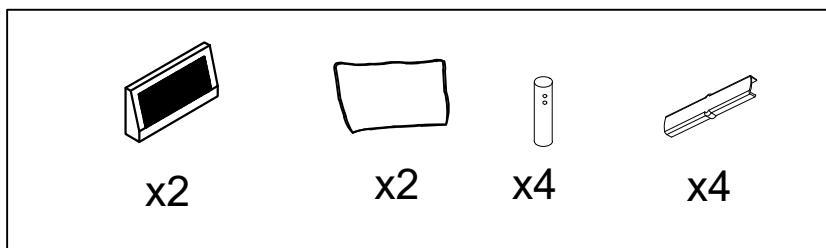
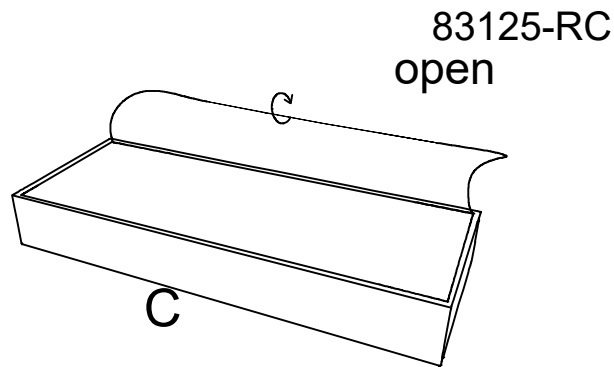
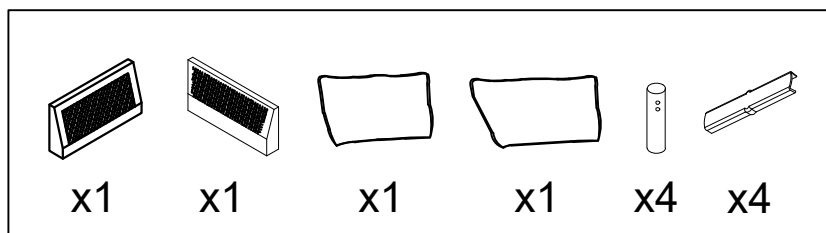

## ASSEMBLY INSTRUCTIONS

### ASSEMBLY TIPS:

1. Remove hardware from box and sort by size.
2. Please check to see that all hardware and parts are present prior to start of assembly.
3. Please follow attached instructions in the same sequence as numbered to assure fast & easy assembly.

### WARNING!

1. Don't attempt to repair or modify parts that are broken or defective. Please contact the store immediately.
2. This product is for home use only and not intended for commercial establishments.

#### HARDWARE PACK IS LOCATED IN 83125-RC

1	BOLT (5/16" x 80mm -RBW)		8
2	CLOCK WASHER (5/16" x 12mm -RBW )		8
3	FLAT WASHER ( 5/16" x 19mm -RBW )		8
4	ALLEN WRENCH (75mm - RBW )		1

#### HARDWARE PACK IS LOCATED IN 83125-L

1	BOLT (5/16" x 80mm -RBW)		8
2	CLOCK WASHER (5/16" x 12mm -RBW )		8
3	FLAT WASHER ( 5/16" x 19mm -RBW )		8
4	ALLEN WRENCH (75mm - RBW )		1

#### HARDWARE PACK IS LOCATED IN 83125-LC

1	BOLT (5/16" x 80mm -RBW)		8
2	CLOCK WASHER (5/16" x 12mm -RBW )		8
3	FLAT WASHER ( 5/16" x 19mm -RBW )		8
4	ALLEN WRENCH (75mm - RBW )		1

# ASSEMBLY INSTRUCTIONS

## STEP 1

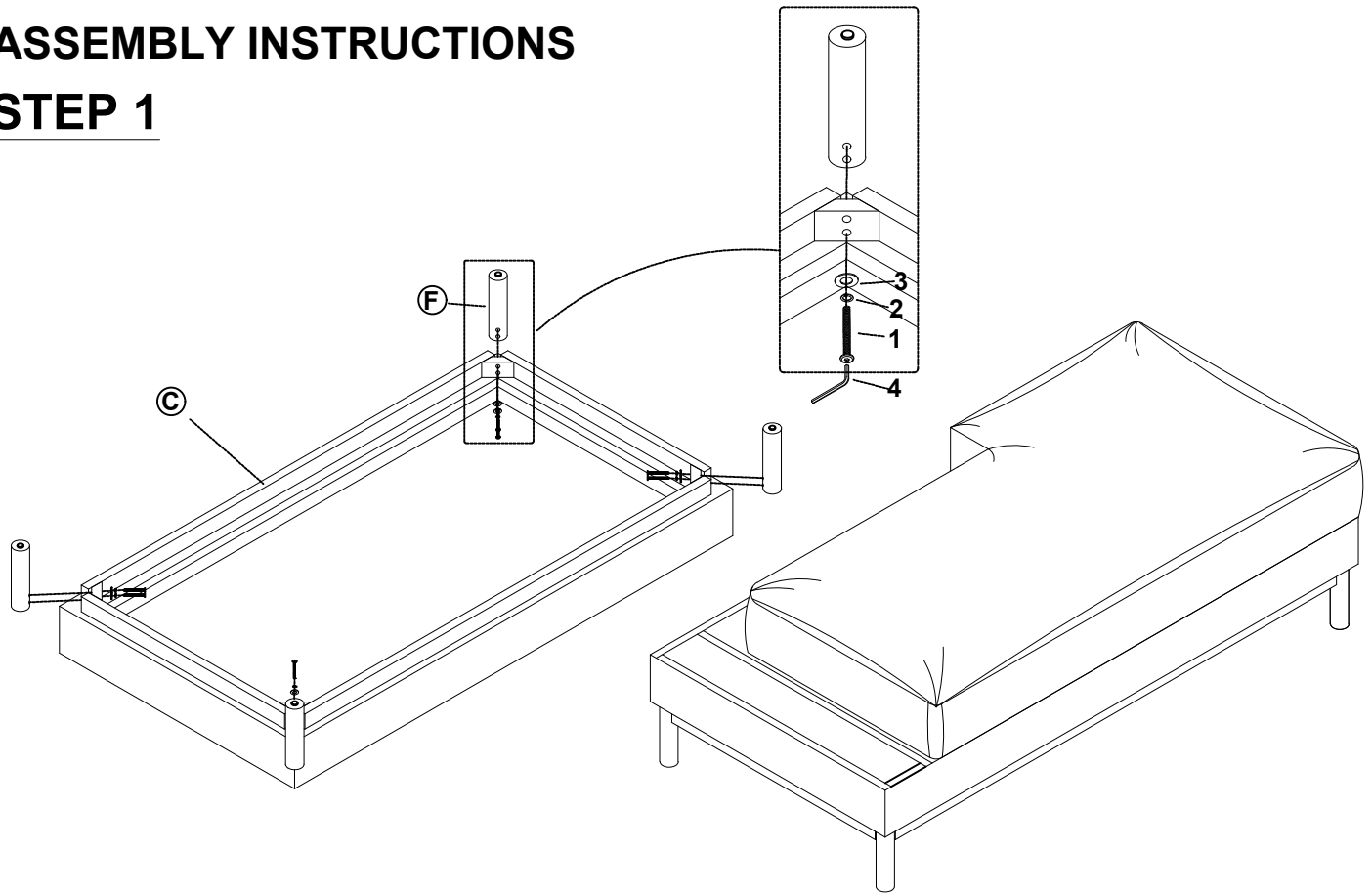

## STEP 2

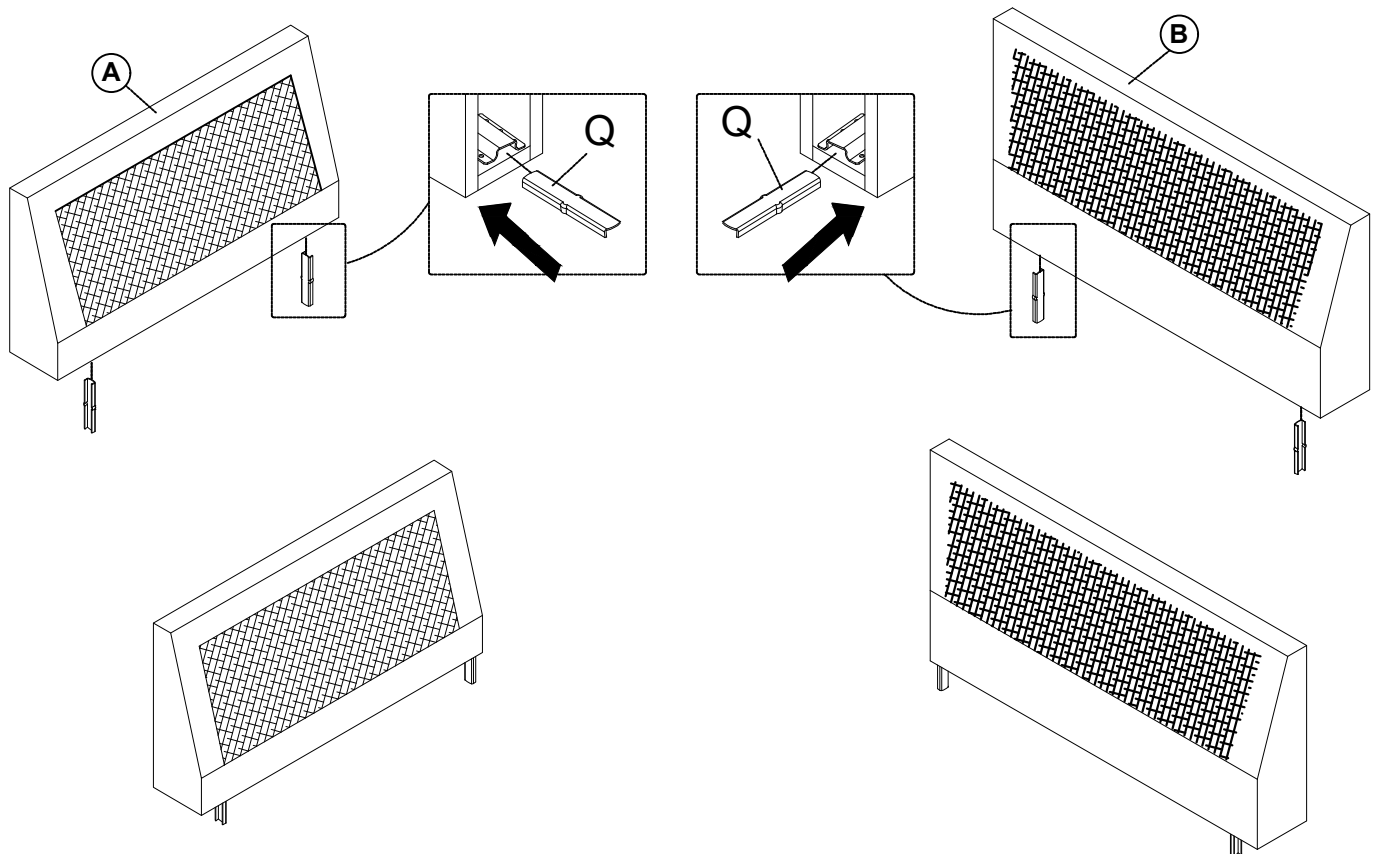

# ASSEMBLY INSTRUCTIONS

## STEP 3

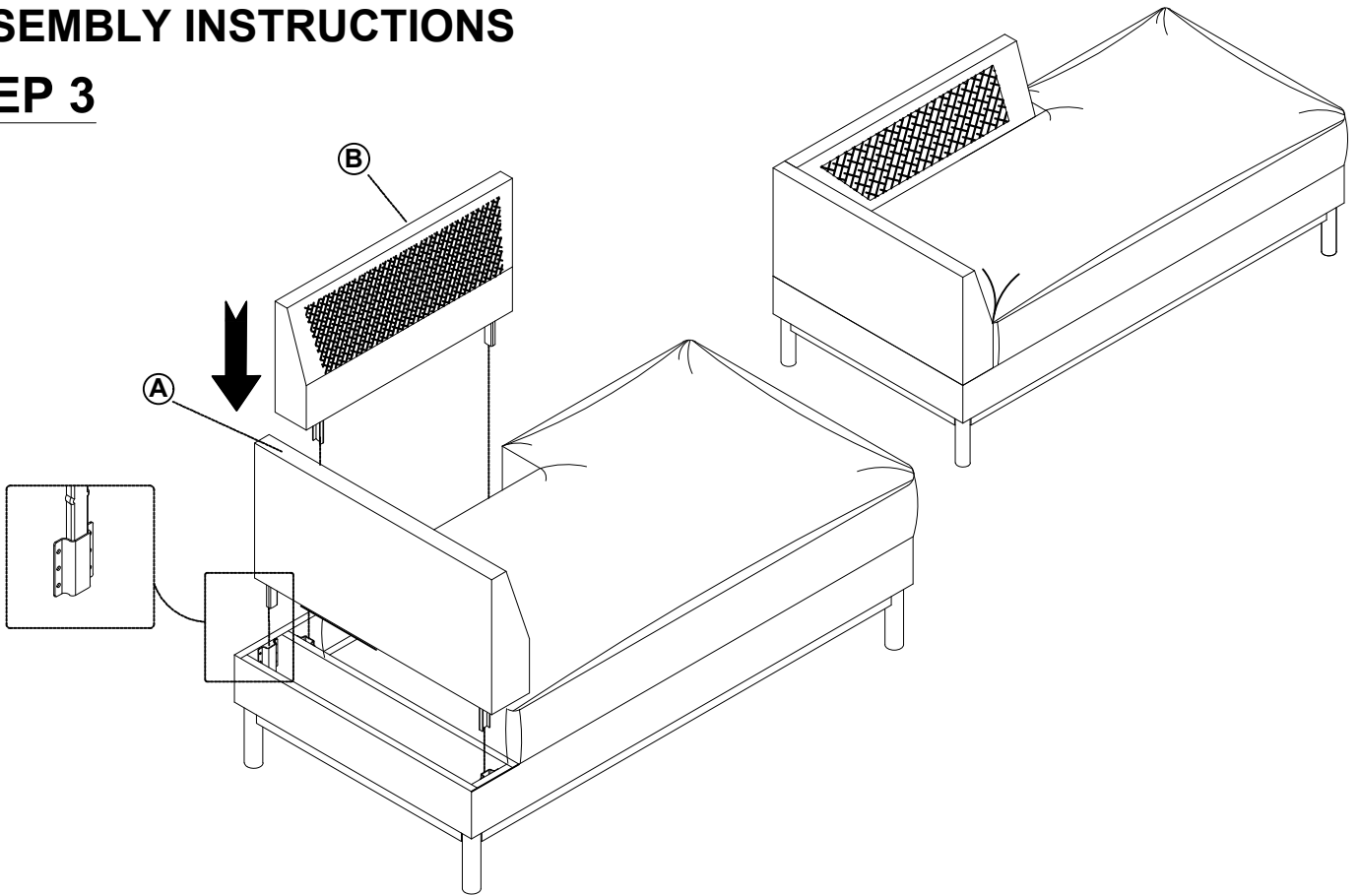

## STEP 4

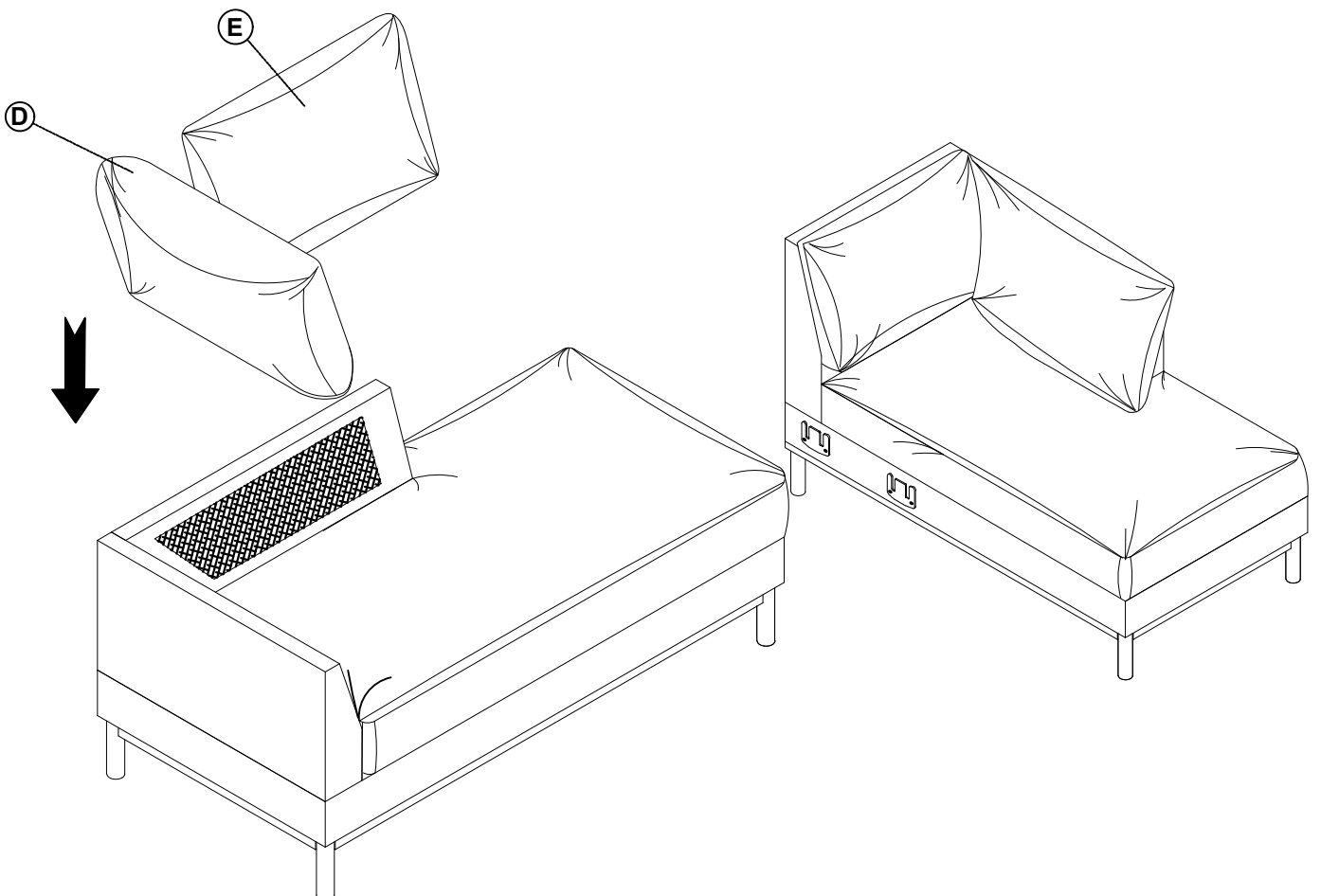

# ASSEMBLY INSTRUCTIONS

## STEP 5

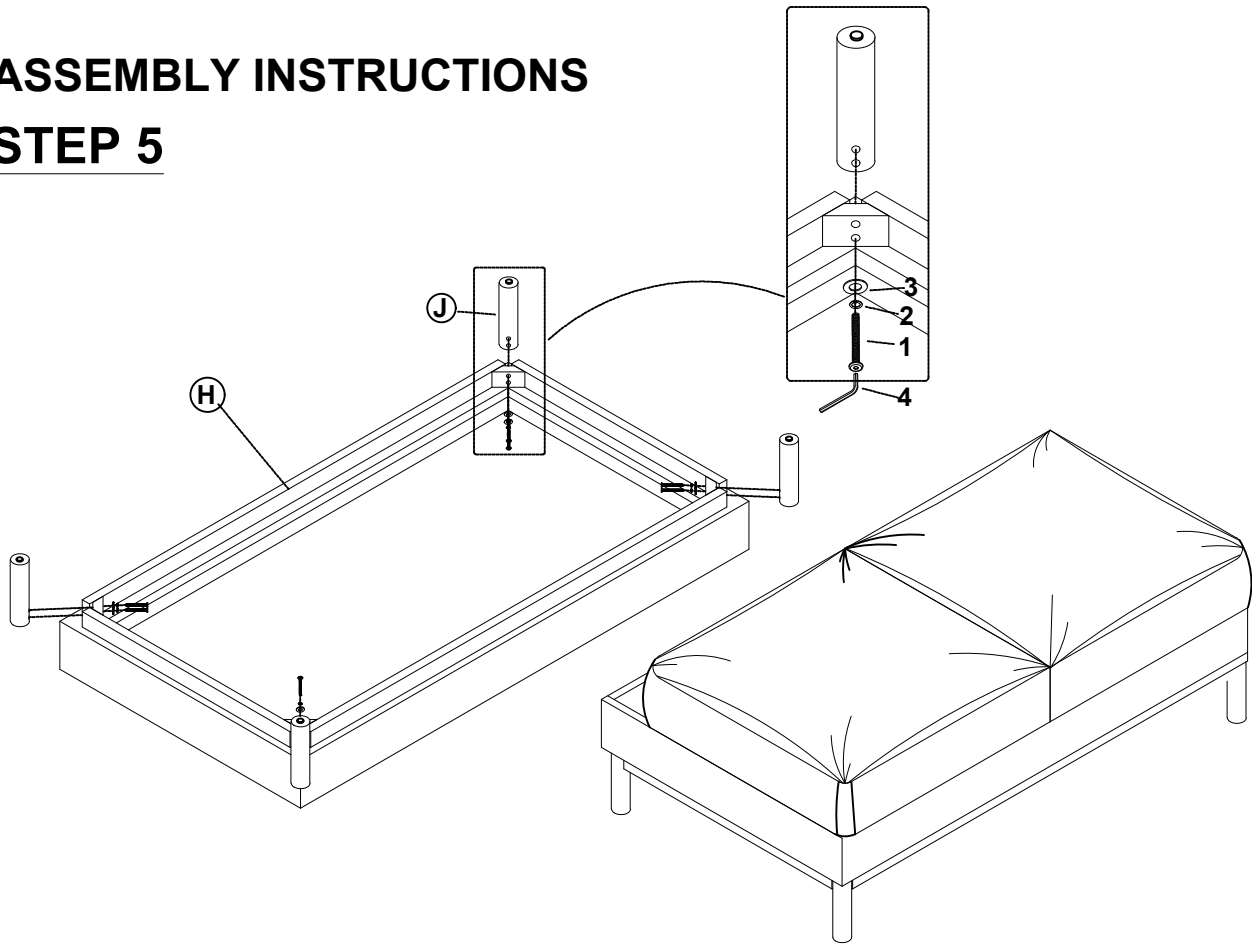

## STEP 6

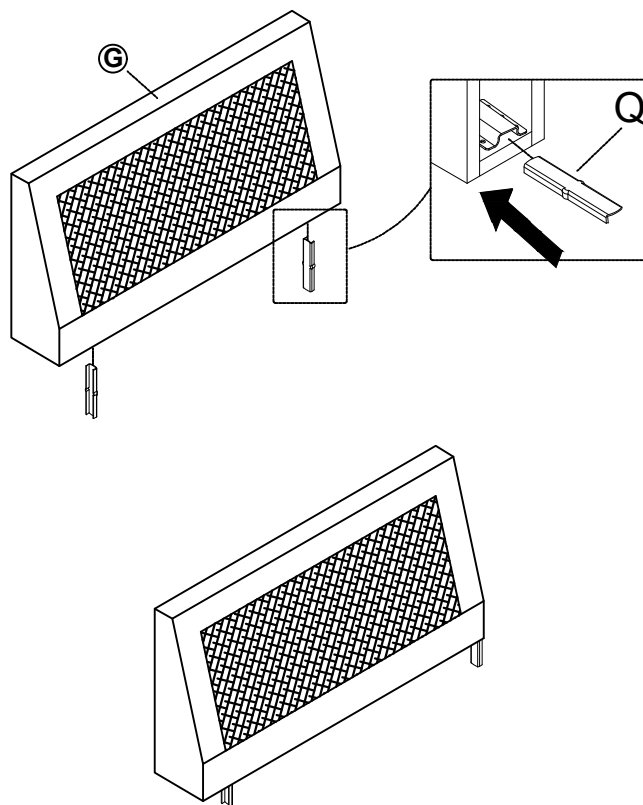

# ASSEMBLY INSTRUCTIONS

## STEP 7

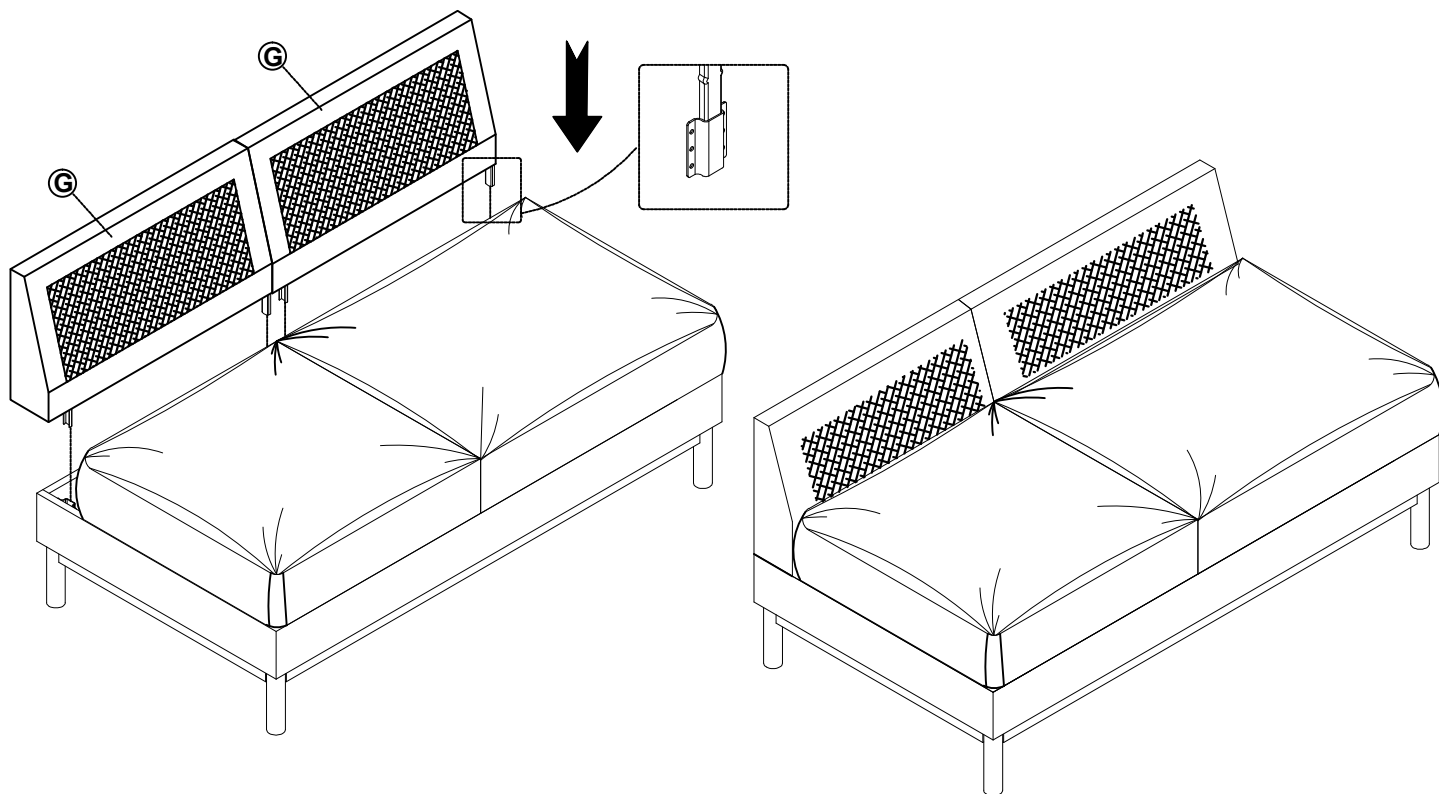

## STEP 8

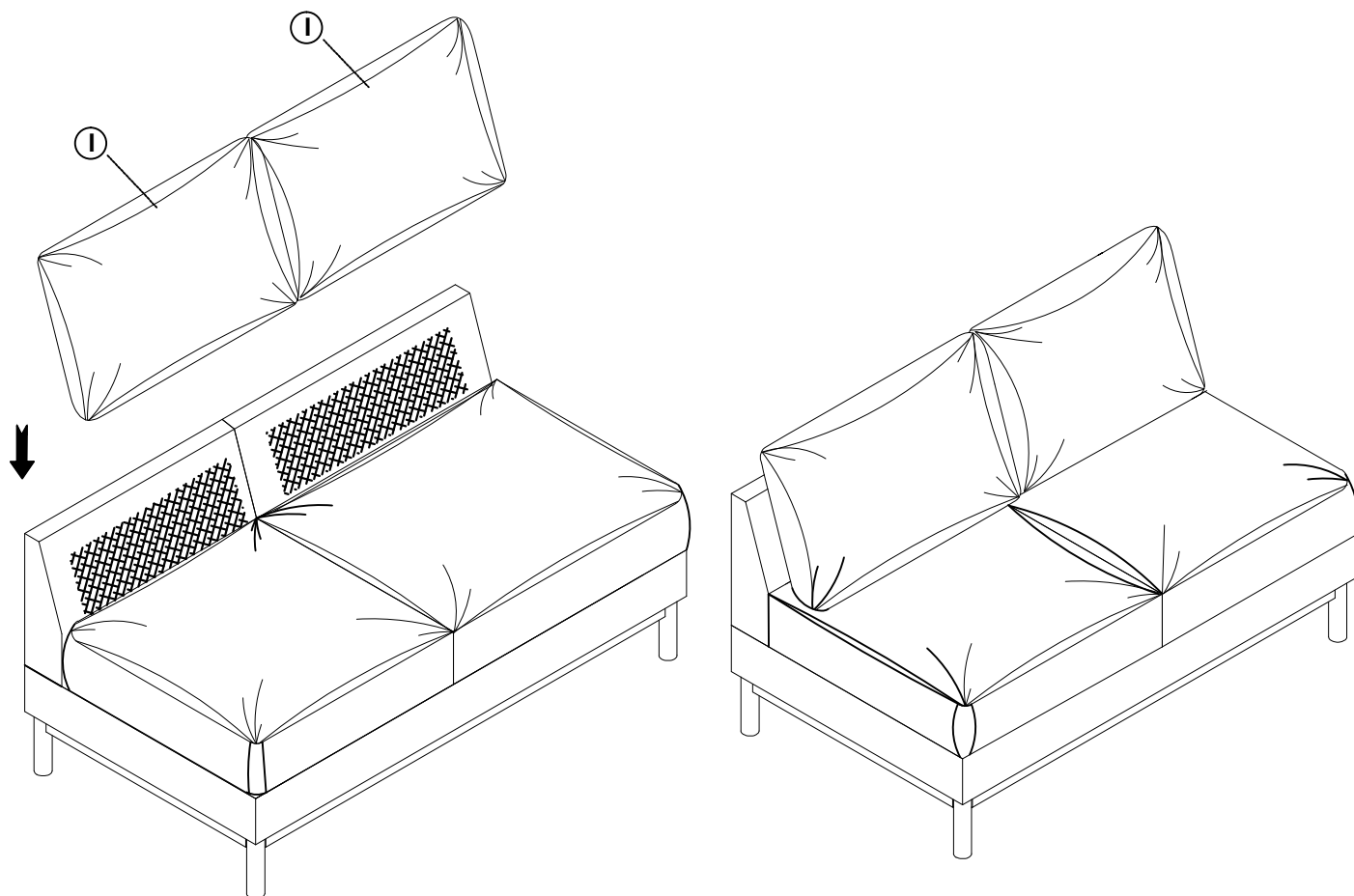

# ASSEMBLY INSTRUCTIONS

## STEP 9

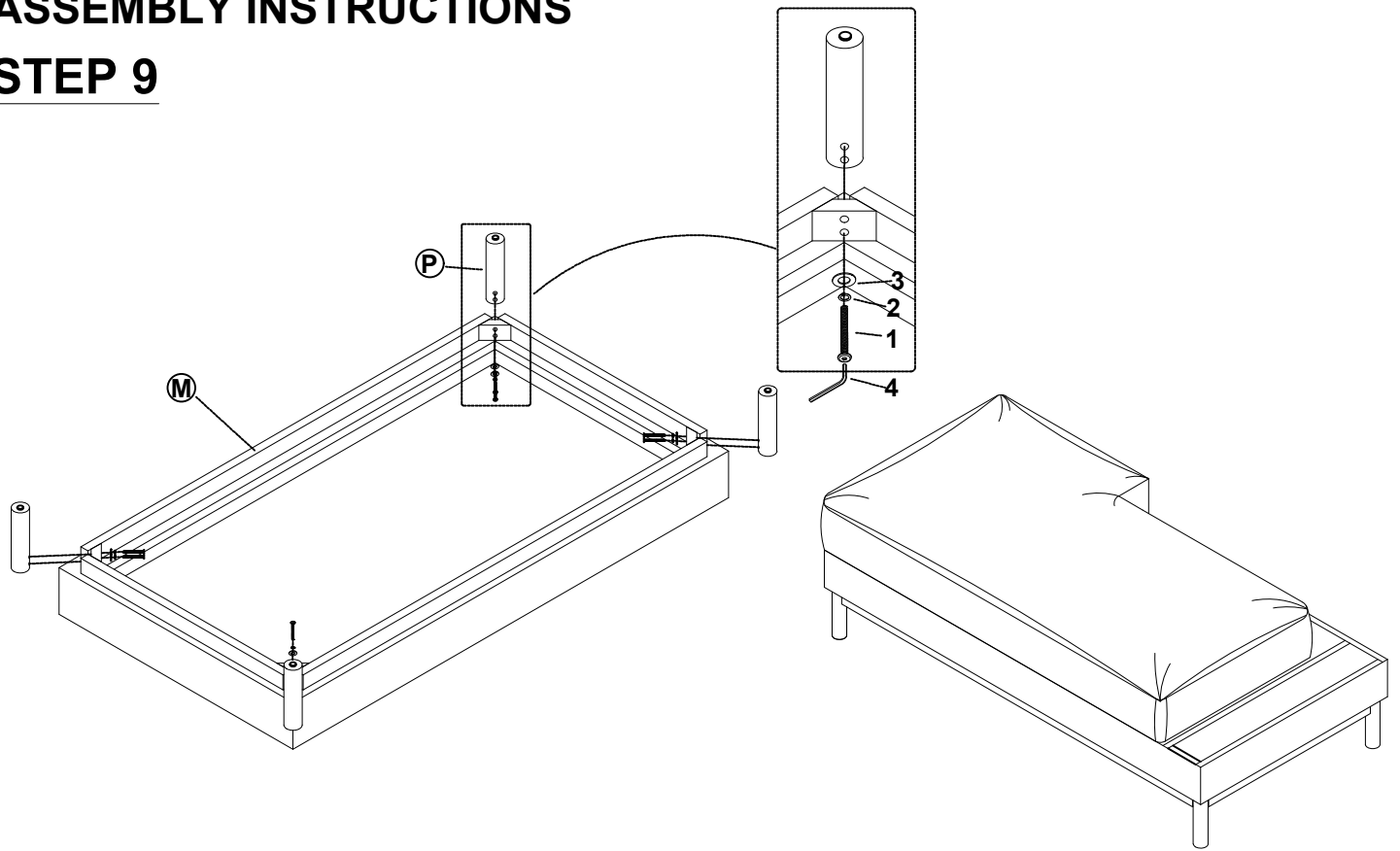

## STEP 10

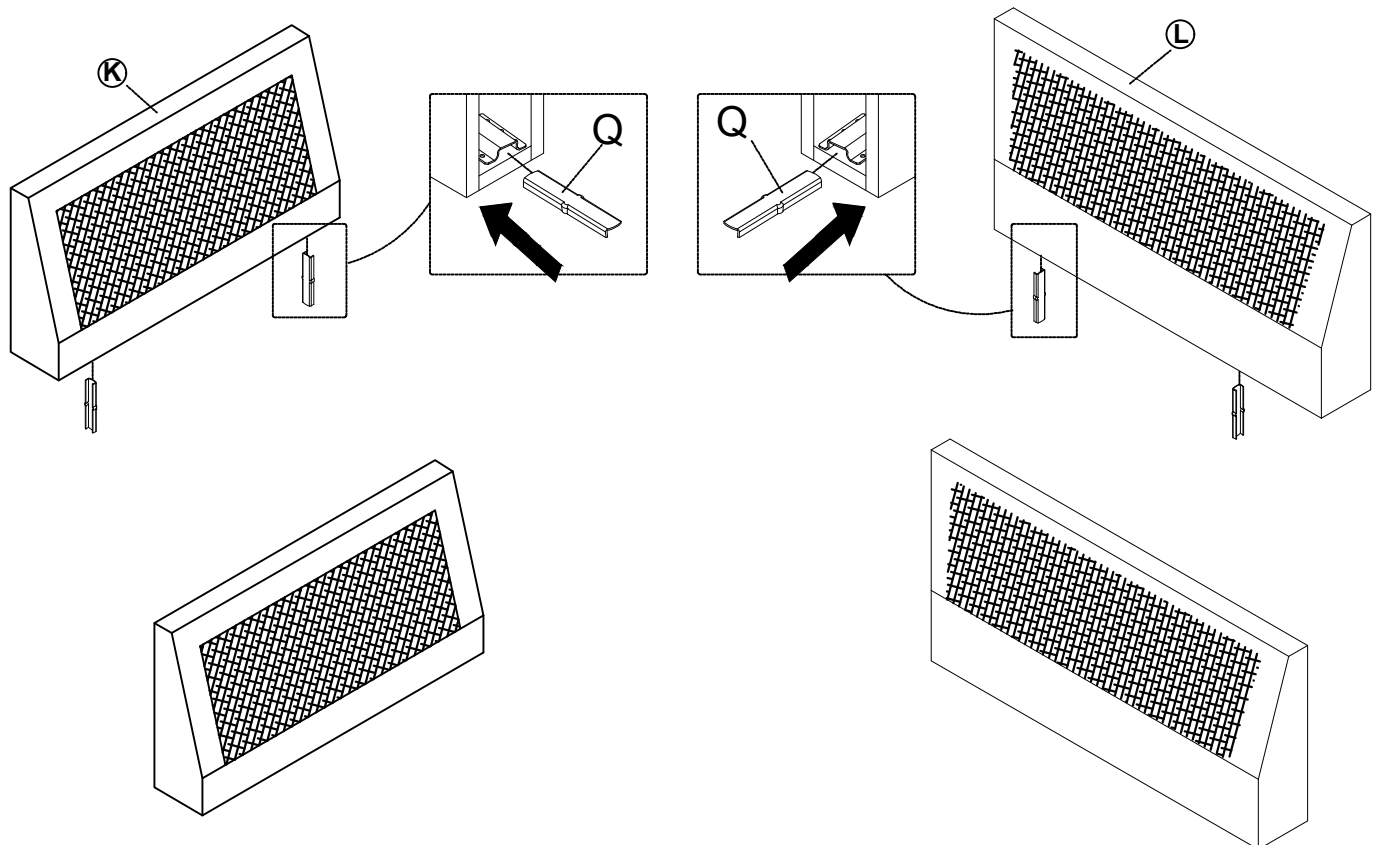

# ASSEMBLY INSTRUCTIONS

## STEP 11

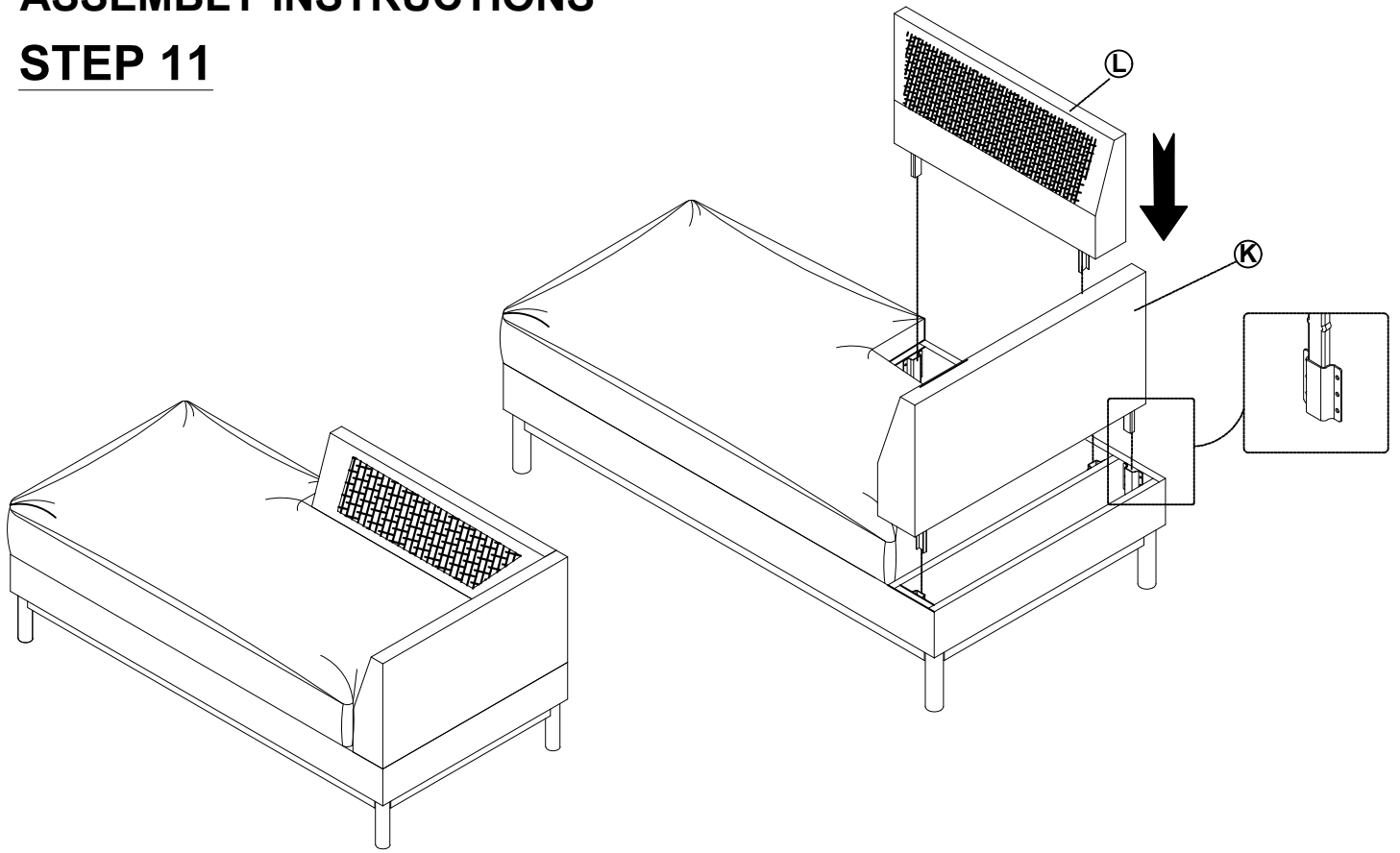

## STEP 12

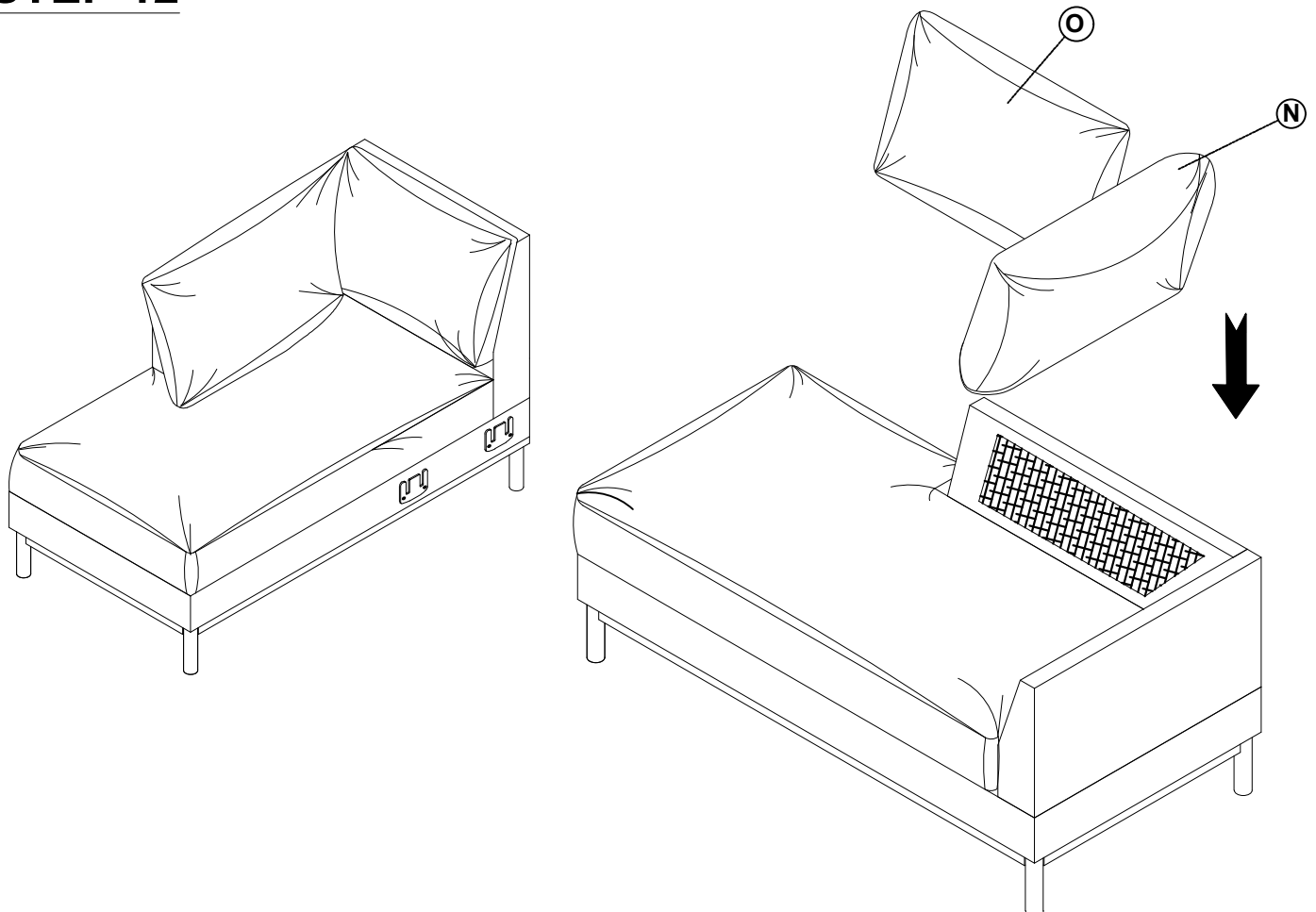



# ASSEMBLY INSTRUCTIONS

