

# ASSEMBLY INSTRUCTION

ITEM NO.: 89114-C

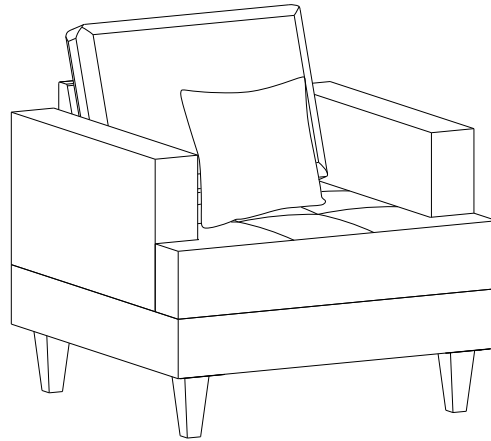

## PARTS IDENTIFICATION

### CHAIR WITH 1PCS PILLOW

A CHAIR ARM

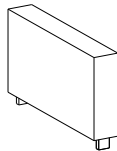

2PCS

B BACKREST

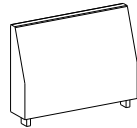

1PC

C SEAT BODY

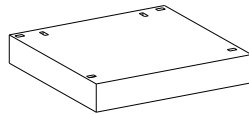

1PC

D BACK CUSHION

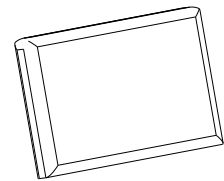

1PC

E SEAT CUSHION

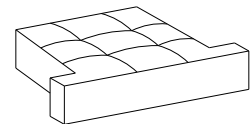

1PC

F PILLOW

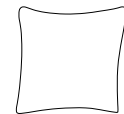

1PC

### HARDWARE PACK

1 FLAT WASHER  
(2MM-BLK)



16PCS

2 BOLT  
(25MM-BLK)

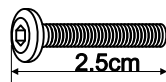

16PCS

3 HEXAGON  
WRENCH  
(75MM-BLK)

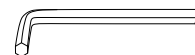

1PC

4 LEG

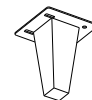

4PCS

# ASSEMBLY INSTRUCTION

ITEM NO.: 89114-C

STEP 1: Remove all Parts from box.

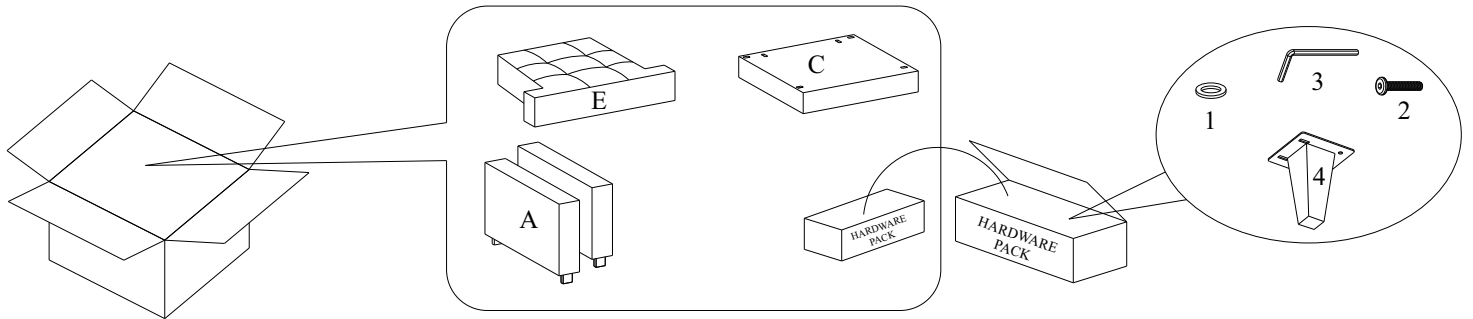

STEP 2: Remove Back Cushion (D) and Backrest (B) from Seat Body (C).

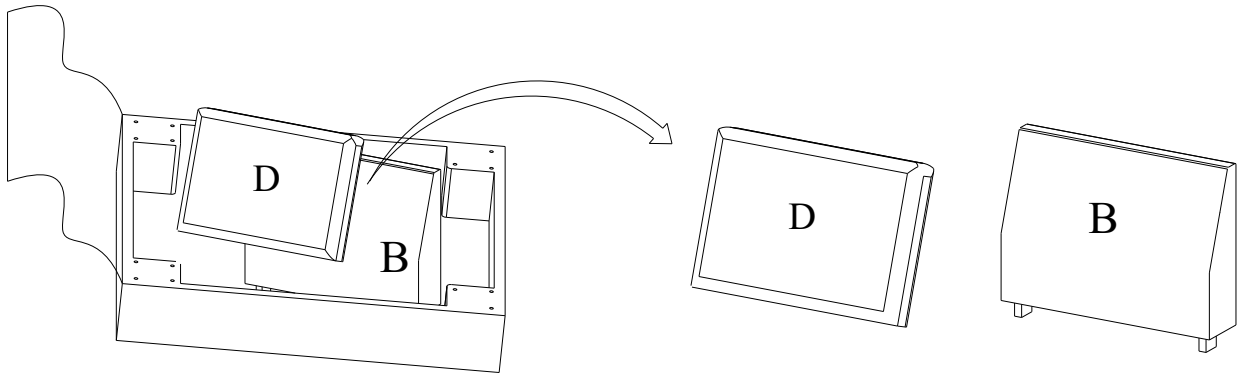

STEP 3: Paste the cover under the Seat Body (C) before doing the next step.

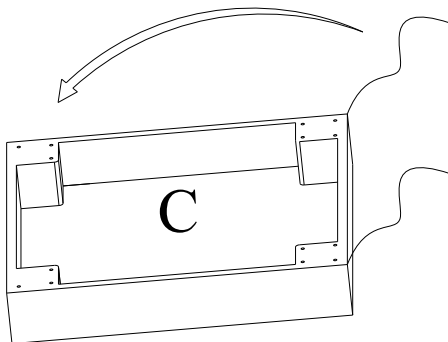

STEP 4: Attach Legs (4) to the Seat Body (C).

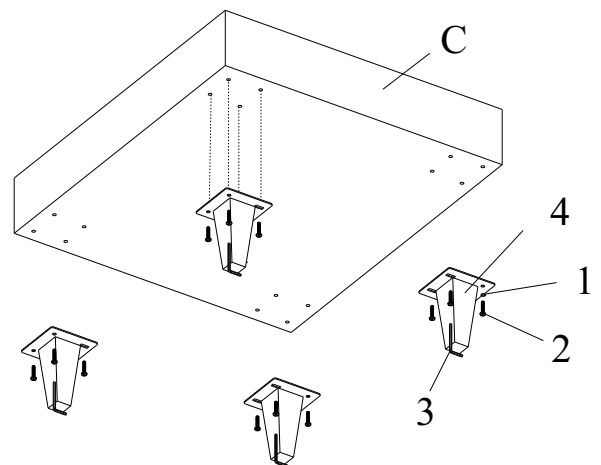

# ASSEMBLY INSTRUCTION

ITEM NO.: 89114-C

STEP 5: Attach Backrest (B) and Arms (A) to the Seat Body (C)

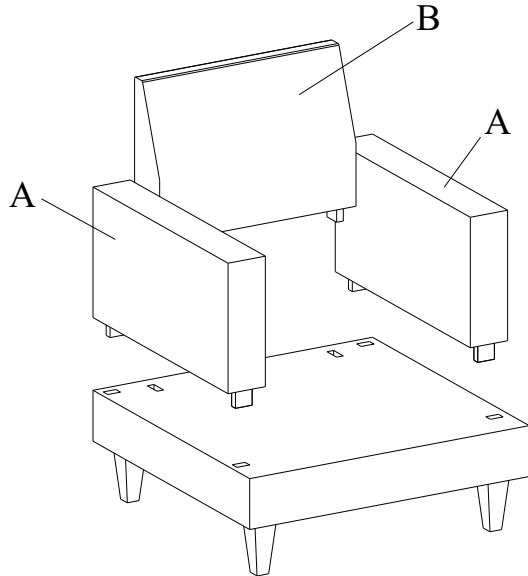

STEP 6: Put Seat Cushion (E) above the Seat Body (C)

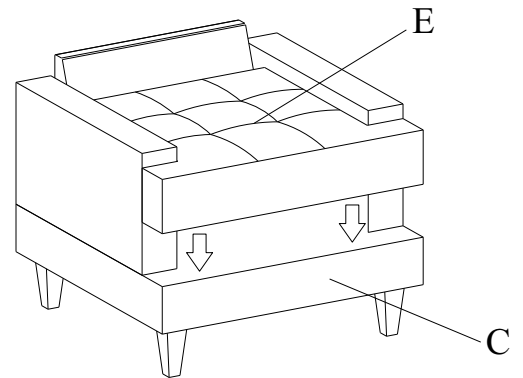

STEP 7: Put the Back Cushion (D) and Pillow (F) in front of the Backrest (B)

