

ASSEMBLY INSTRUCTIONS

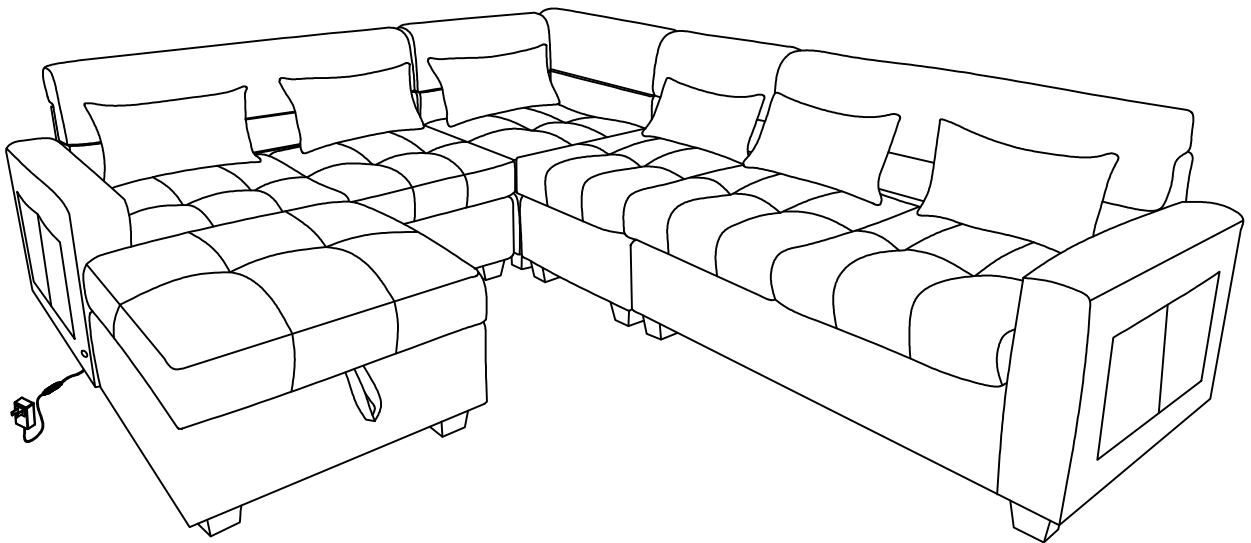



89306

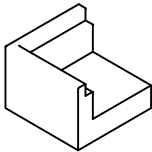
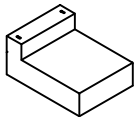
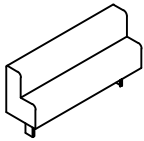
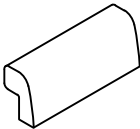
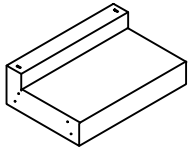
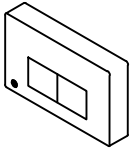
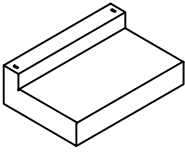
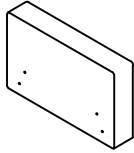
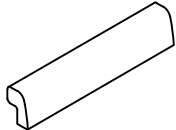
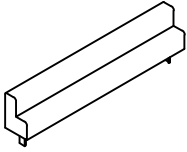
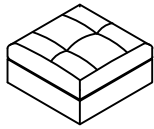
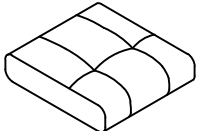

ASSEMBLY INSTRUCTIONS

89306

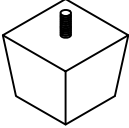
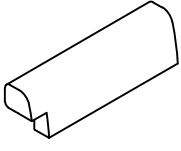
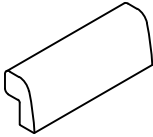



PART LISTS: 89306

A  1 pc	B  1 pc	C  1 pc
D  1 pc	E  1 pc	F  1 pc
G  1 pc	H  1 pc	I  1 pcs
J  2 pcs	K  1 pc	L  6 pcs
M  6 pcs	N  20 pcs	P  1 pc
Q  1 pc	O  1 pc	

ASSEMBLY INSTRUCTIONS

89306

HARDWARE LISTS: 89306

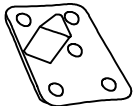
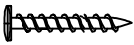
<p>1</p>  <p>Full-thread bolt Ø 5/16"X90mm 8pcs</p>	<p>2</p>  <p>Flat Washer Ø5/16-RBW 8pcs</p>	<p>3</p>  <p>Full-thread bolt 16mmx13mmx13mm 8pcs</p>
<p>4</p>  <p>Open wrench (12mm) 1pc</p>	<p>5</p>  <p>Connector lock 10pcs</p>	<p>6</p>  <p>Screw (M4x30mm) 50pcs</p>

ASSEMBLY INSTRUCTIONS

89306

Step 1:

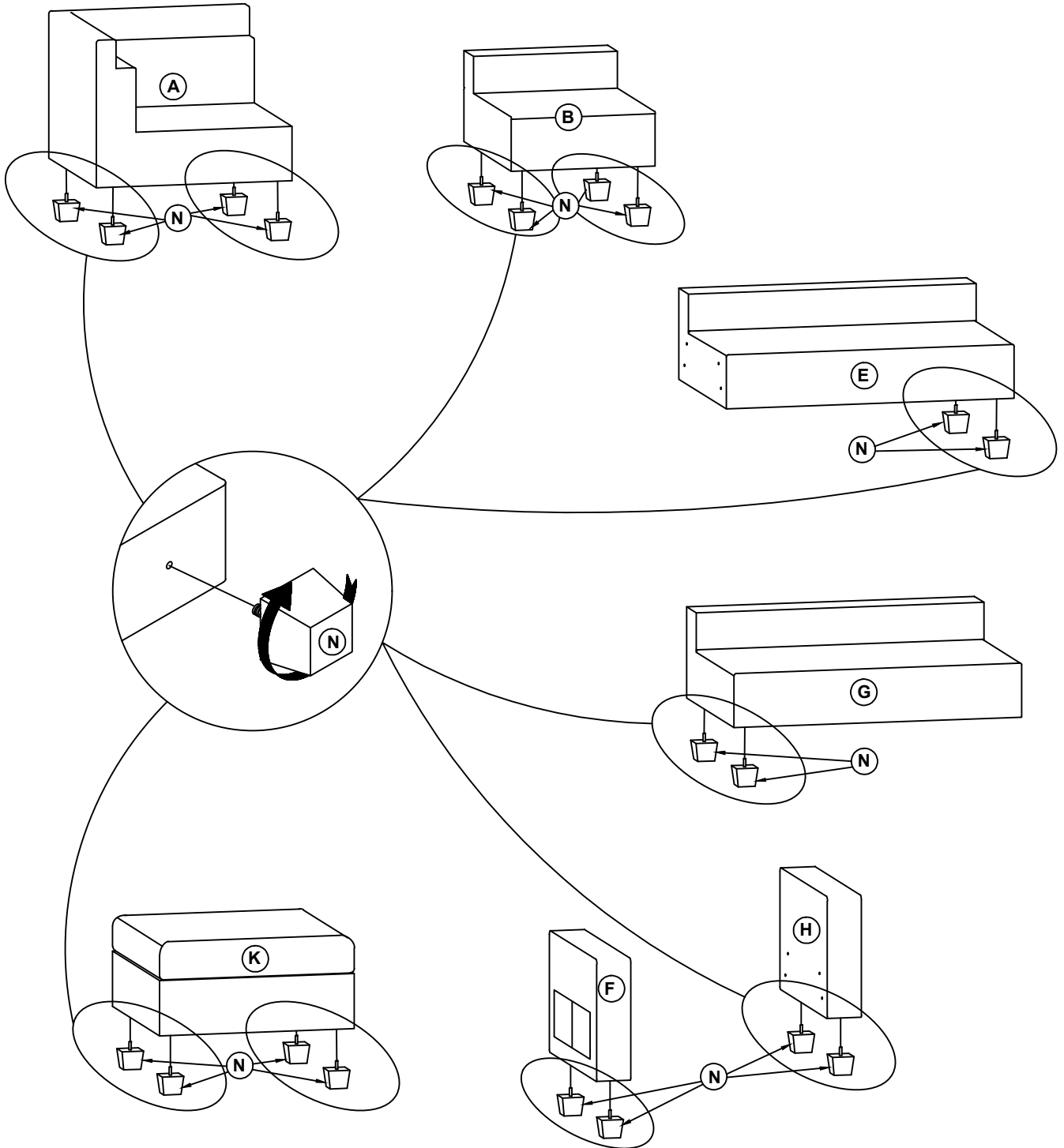

ASSEMBLY INSTRUCTIONS

89306

Step 2:

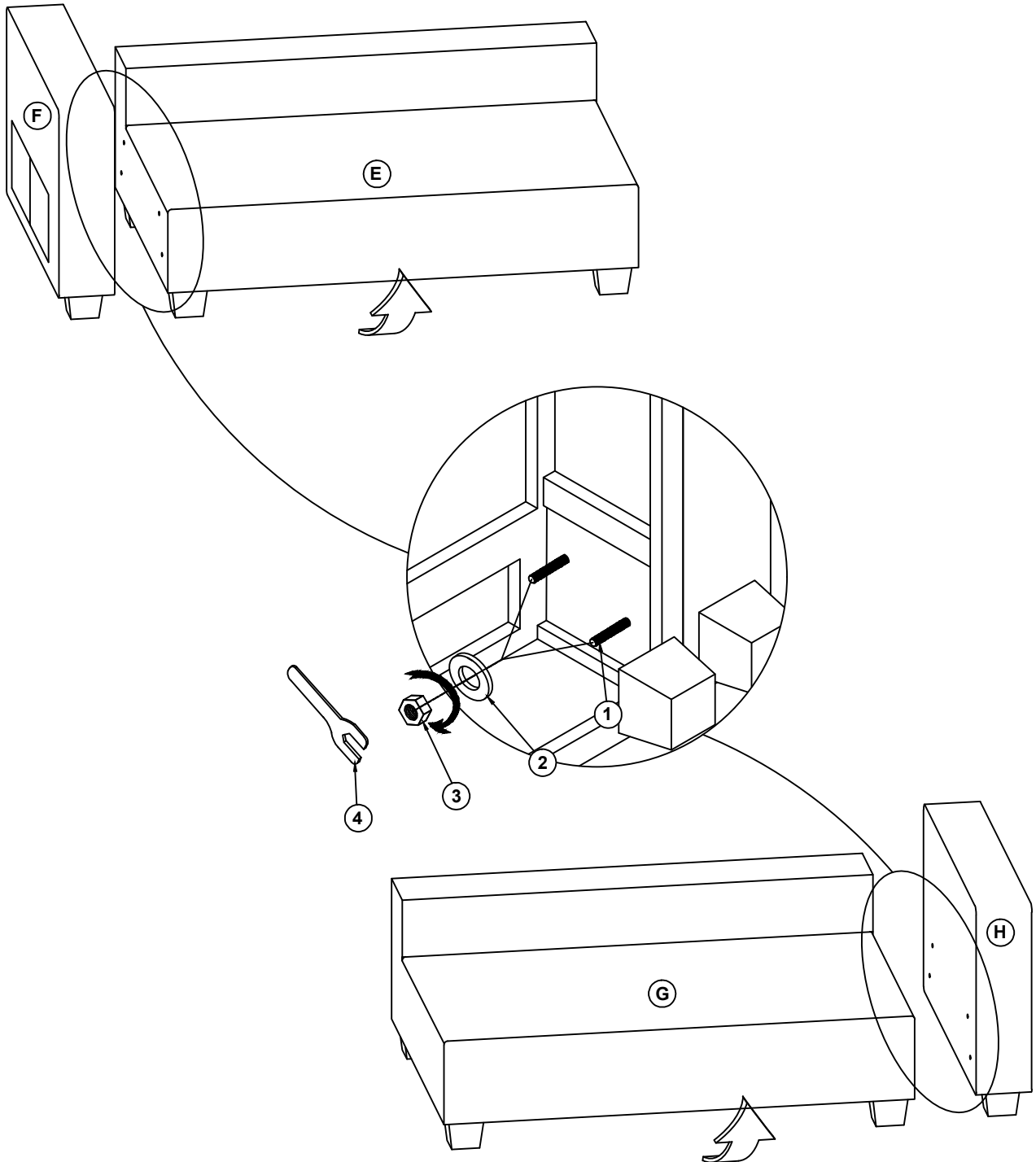

ASSEMBLY INSTRUCTIONS

89306

Step 3:

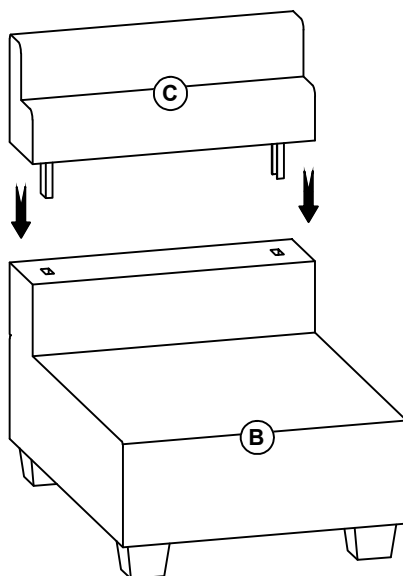
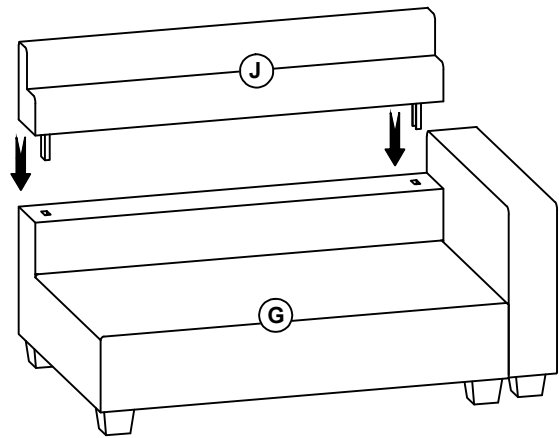
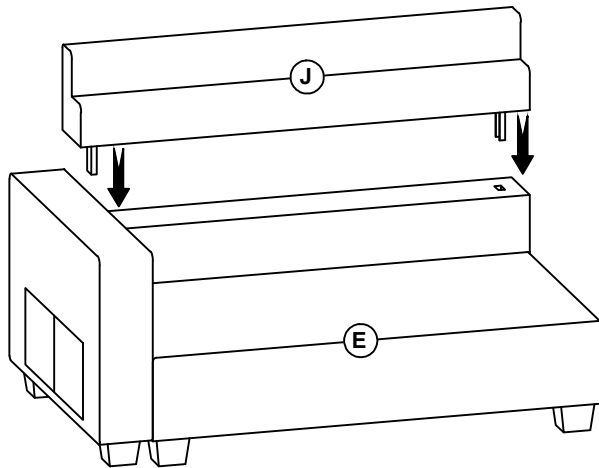

ASSEMBLY INSTRUCTIONS

89306

Step 4:

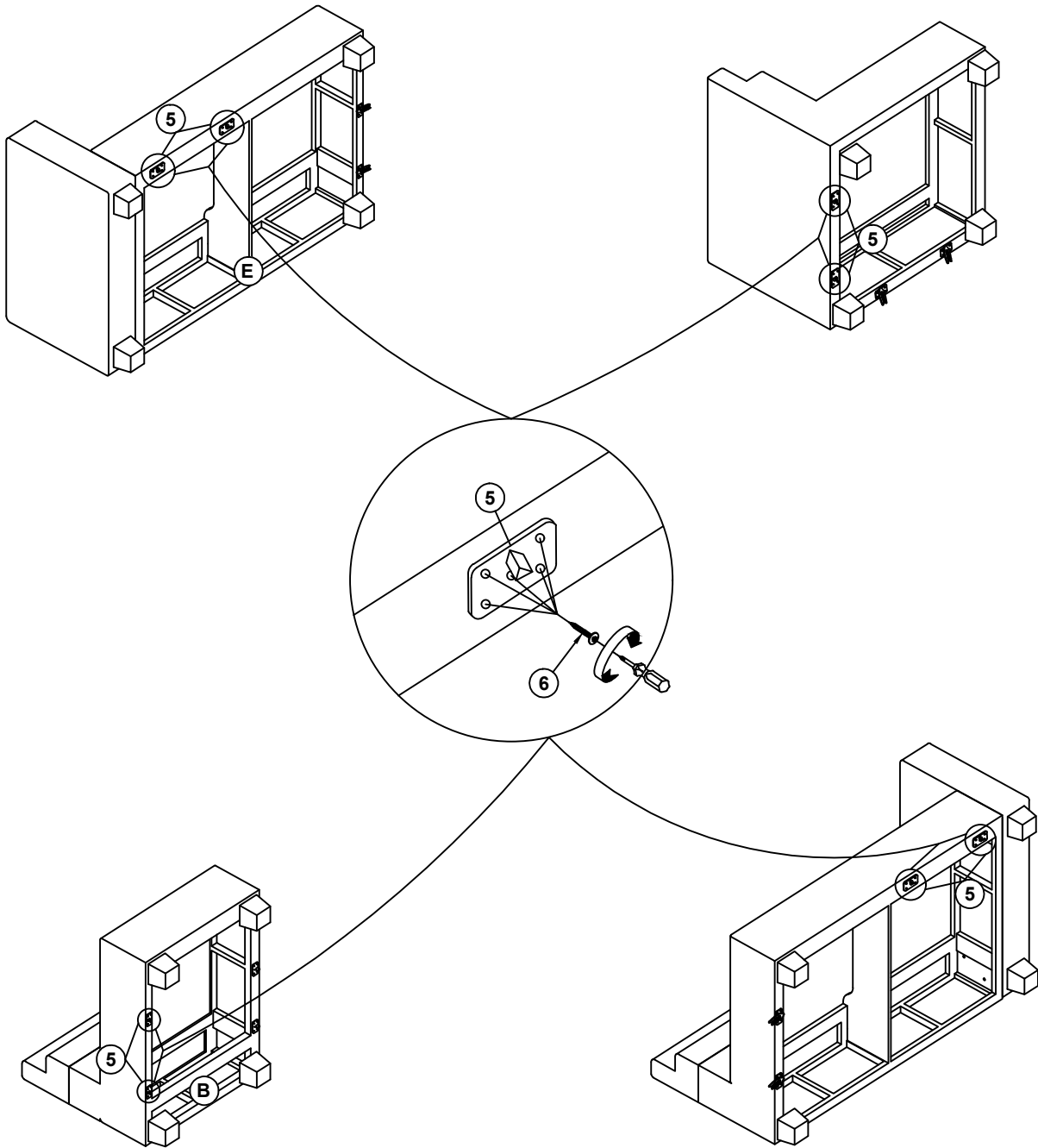

ASSEMBLY INSTRUCTIONS

89306

Step 5:

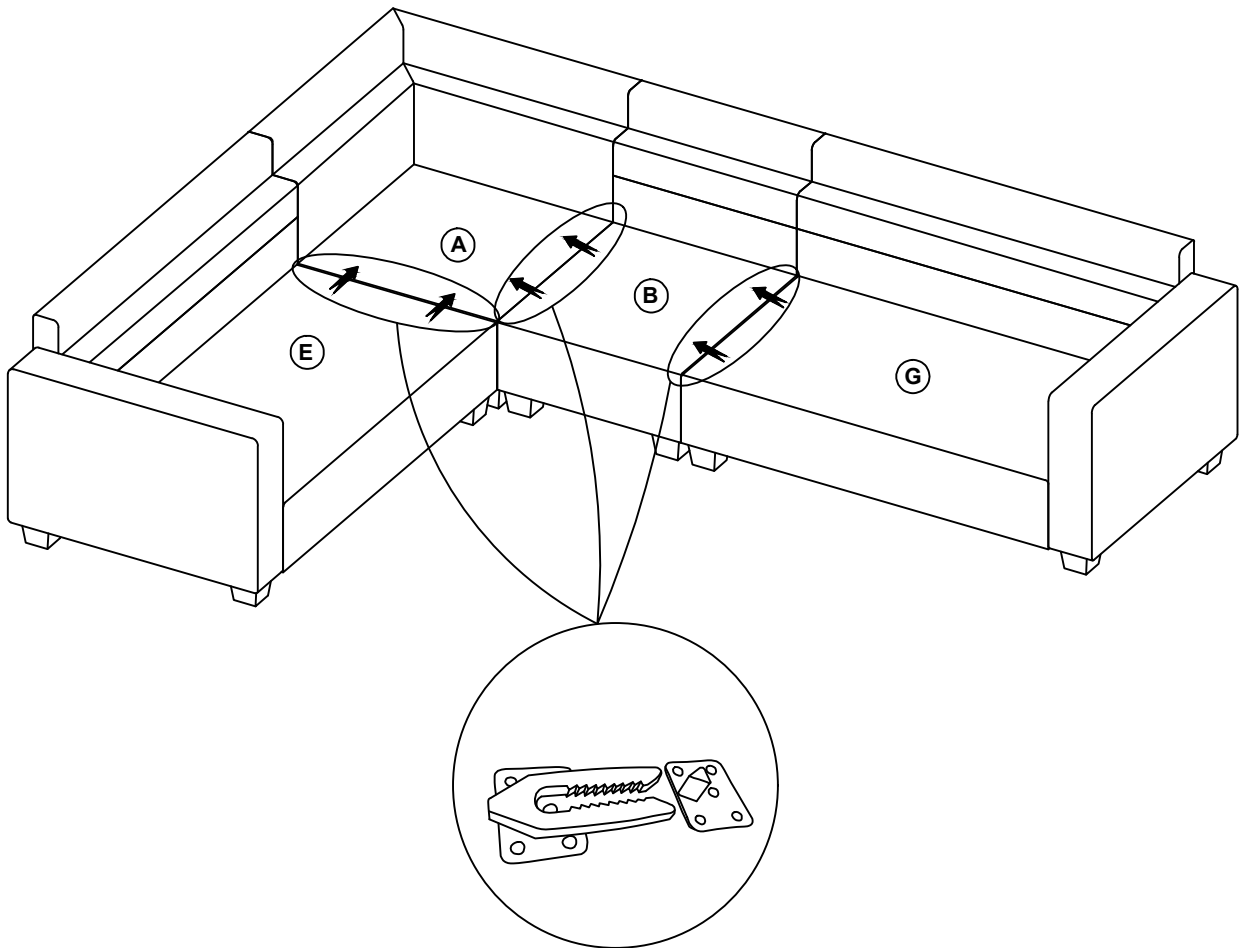

ASSEMBLY INSTRUCTIONS

89306

Step 7:

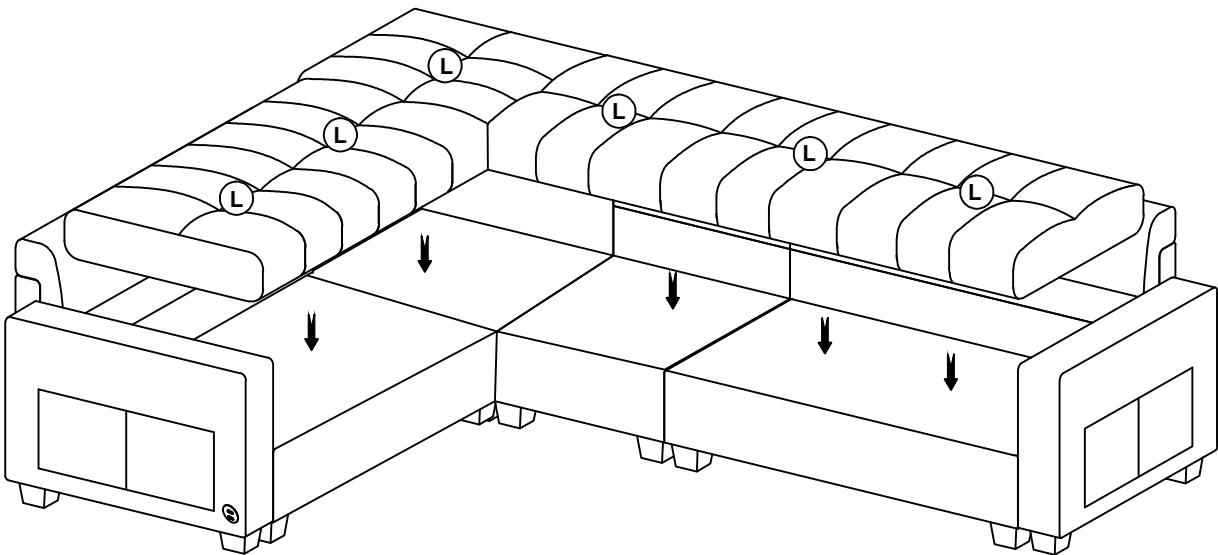

ASSEMBLY INSTRUCTIONS

89306

Step 8:

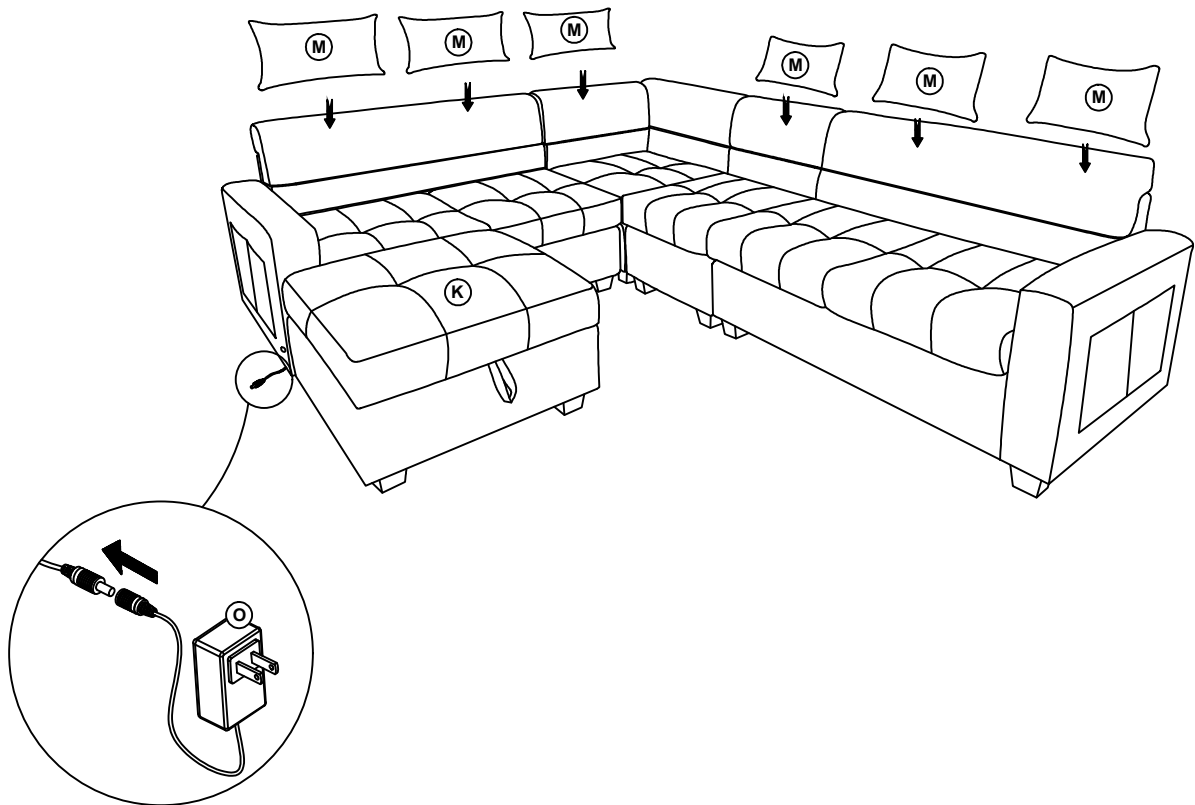

ASSEMBLY INSTRUCTIONS

89306

Step 9:
Complete

