

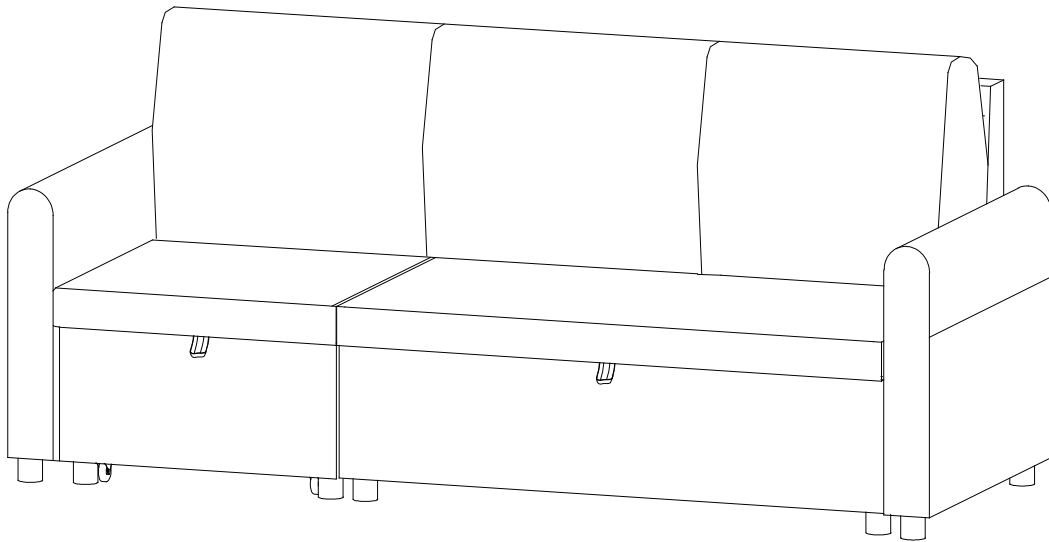





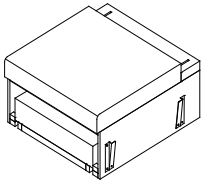
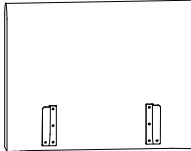
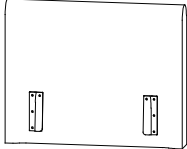
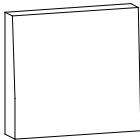

PULL OUT COUCH BED

ASSEMBLY INSTRUCTIONS

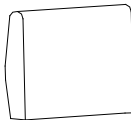
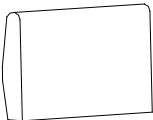

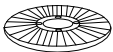
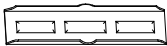
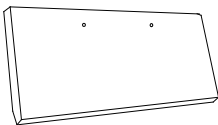
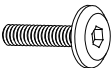
Part No.	Part	Qty	Image	Part No.	Part	Qty	Image
A	Sofa Frame	1		B	Chair Frame	1	
C	Sofa Arm	1		D	Chair Arm	1	
E	Sofa Back	2		F	Chair Back	1	
G	Sofa Back Cushion	2		H	Chair Back Cushion	1	
J	Plastic Leg	12		K	Washer	12	
L	Lock Latches	6		M	Chai Front Fender	1	
N	Allen Bolt	2		O	Allen Washer	2	
P	Allen Wrench	1					

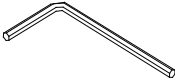
Step 1: Take the Sofa Back (E)x2 & Sofa Back Cushion (G)x2 & Chair Back (F) from Sofa Frame (A); Take the Chair Back cushion (H) & hardware package from Chair Frame (B), legs & hardware would be found in the hardware package.

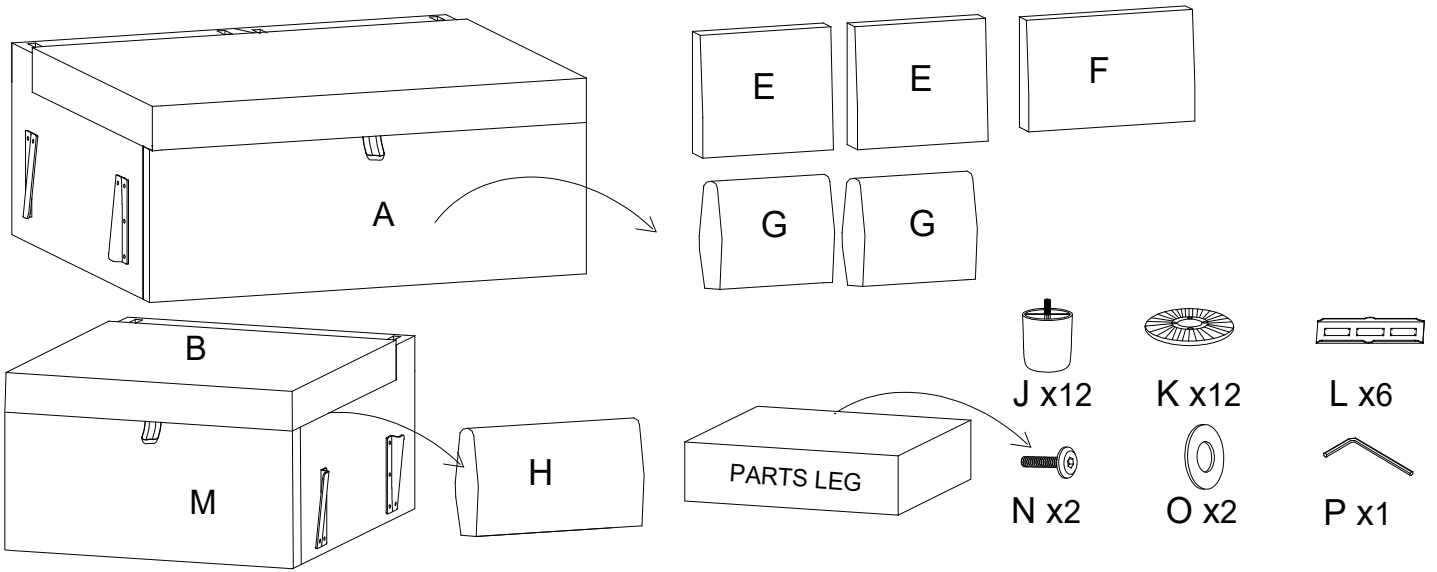

Step 2: Pull part of the bed out, attach Chair Front Fender (M) to Chair Frame (B) with Allen Bolt (N)x2, and Allen Washer (O)x2 by using Allen Wrench (P). Attach the Plastic legs (J)x4 and Washer (K)x4 to the Chair Frame (B).

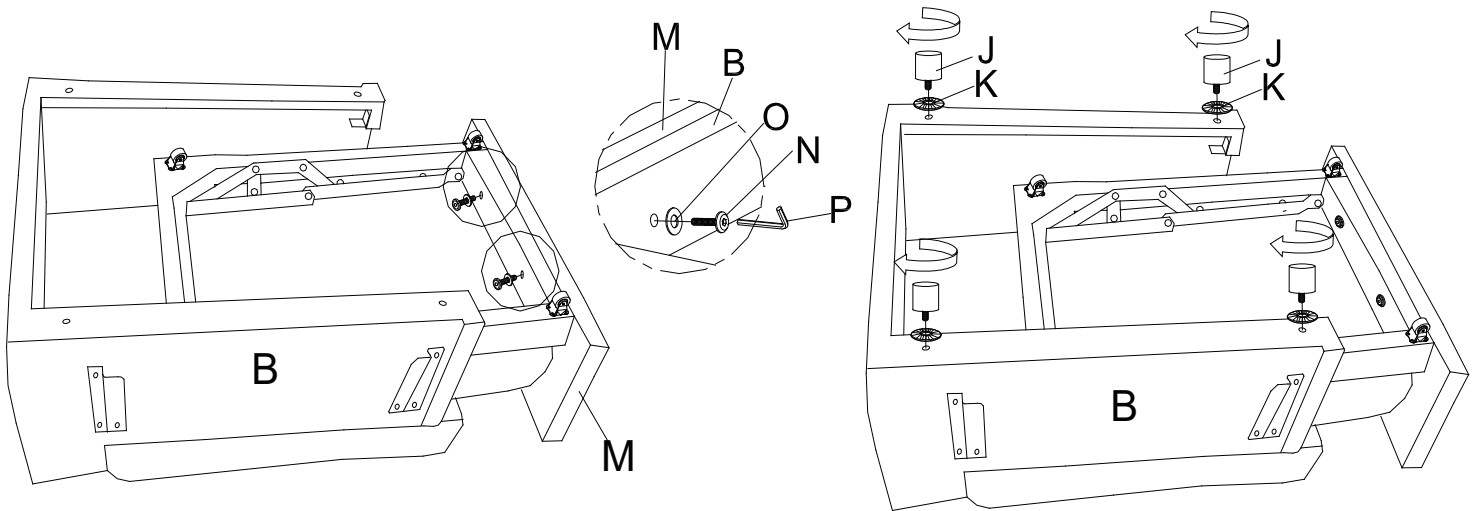

Step 3: Attach the Plastic legs (J)x8 and Washer (K)x8 to the Sofa Frame (A) and the Arm (C&D).

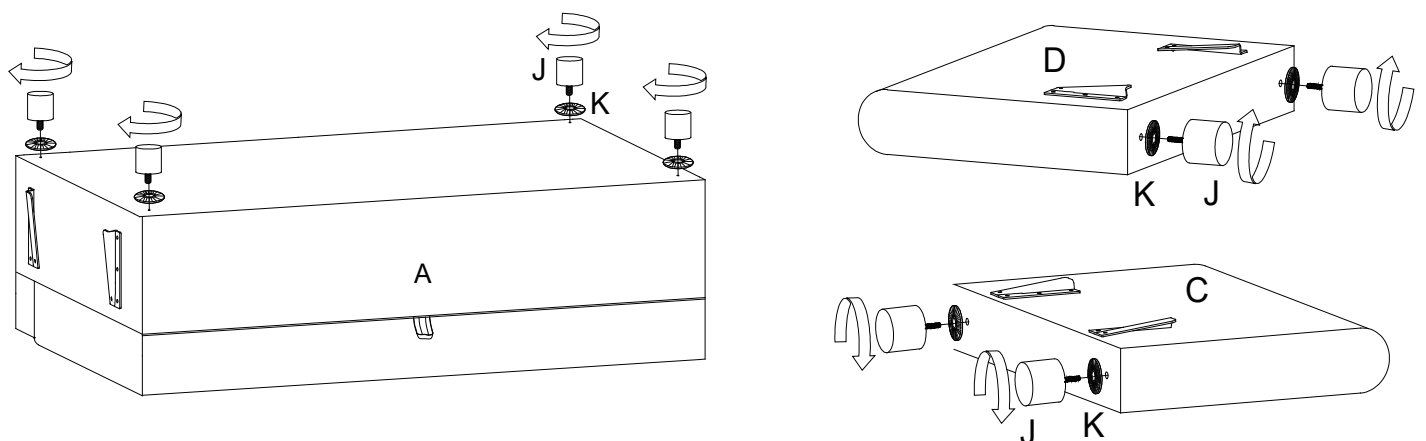

Step4: Style one: Insert the Chair Frame (B) to the Arm (C) . And insert the Arm (D) to the Sofa Frame (A) .Next, connect the Sofa Frame (A) to the Chair Frame (B).

STYLE ONE

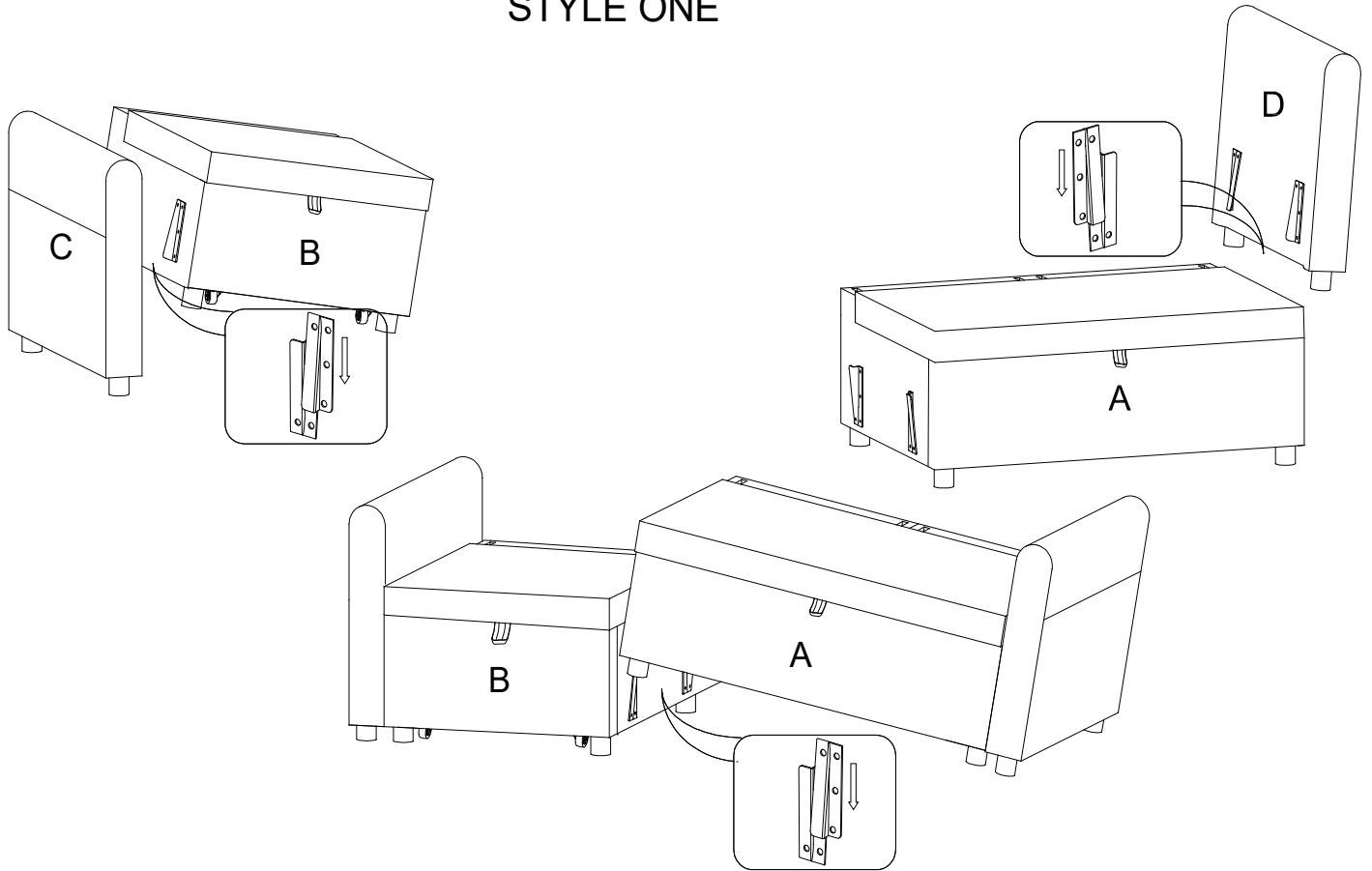

Style two: Insert the Sofa Frame (A) to the Arm (C). And insert the Arm (D) to the Chair Frame (B).Next, connect the Chair Frame (B) to the Sofa Frame (A).

STYLE TWO

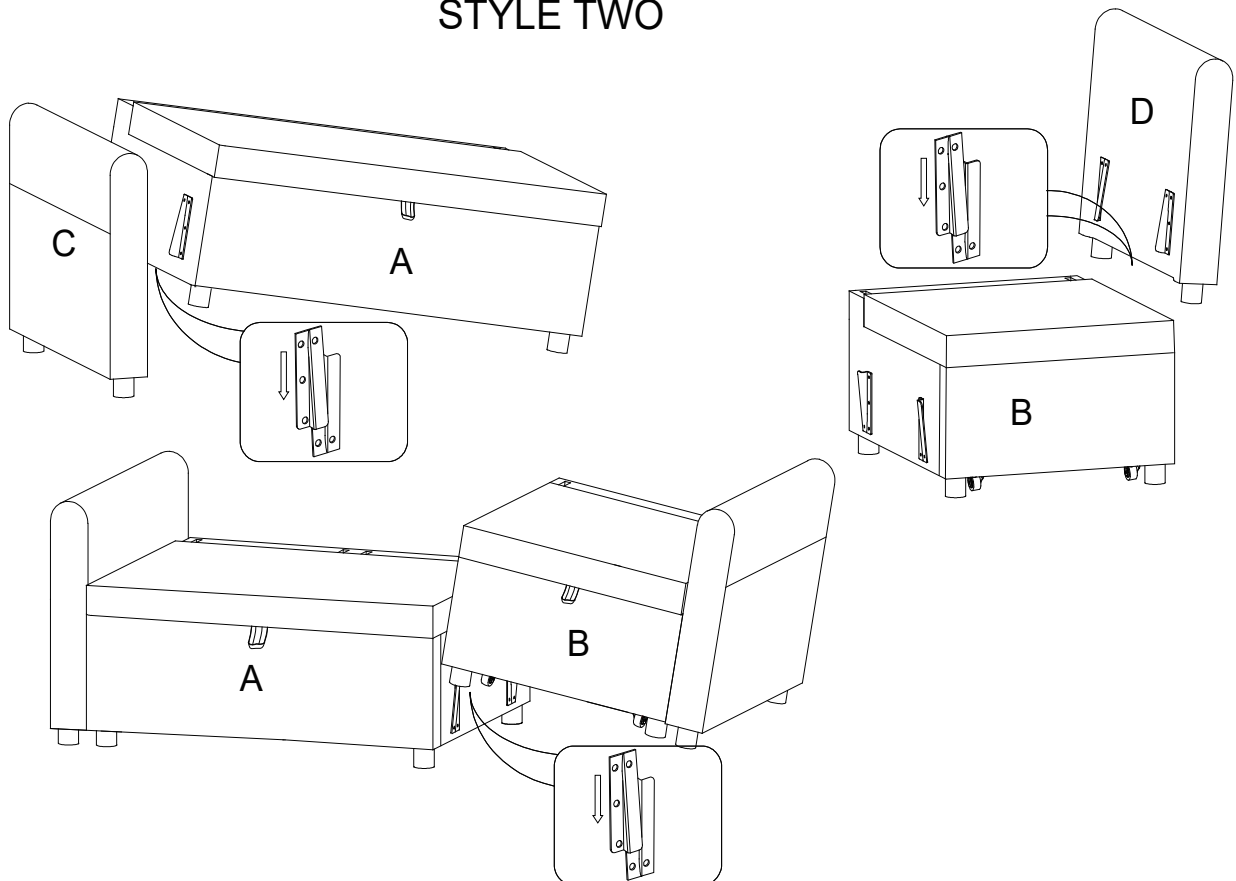

Step5:Insert Lock Latches (L)x6 the Chair Back (F), and the Sofa Back (E).

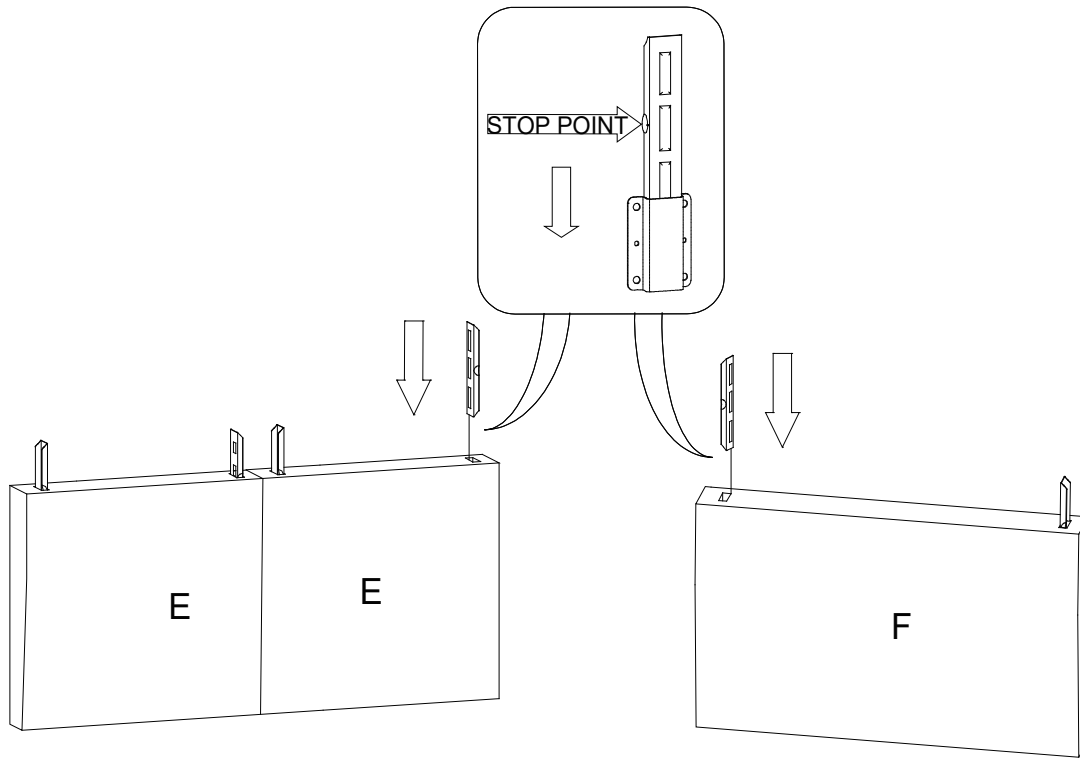

Step6:Insert the Chair Back (F) to the Chair Frame (B).
Insert the sofa Back (E)x2 to the Sofa Frame (A).

STYLE ONE

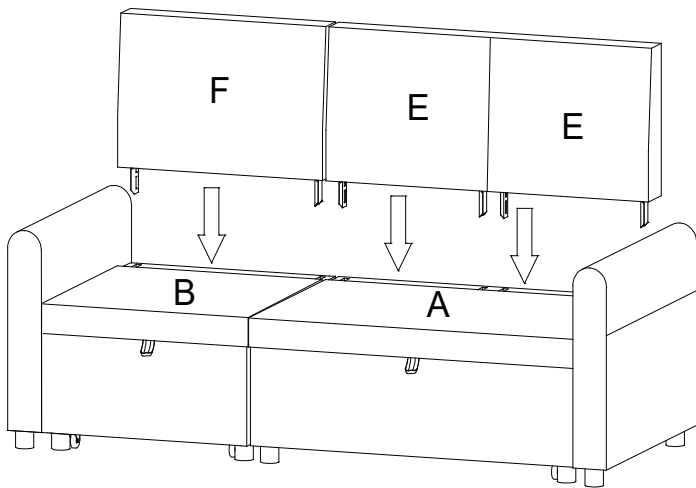

STYLE TWO

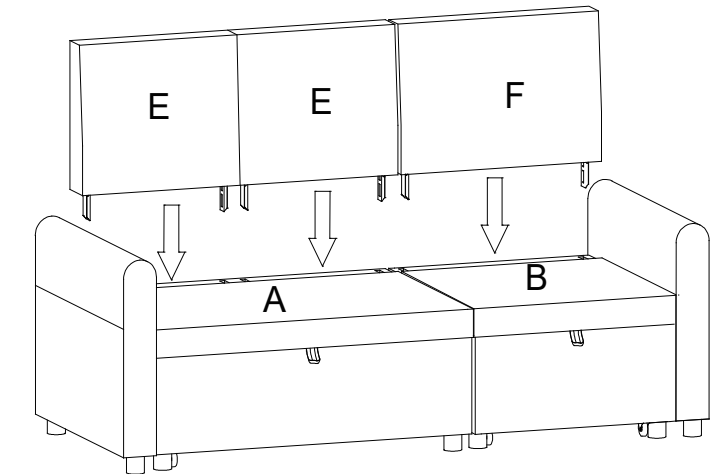

Step7:Put the Chair Back Cushion (H) to the Chair Frame (B).
Insert the Sofa Back Cushion (G)x2 to the Sofa Frame (A).

STYLE ONE

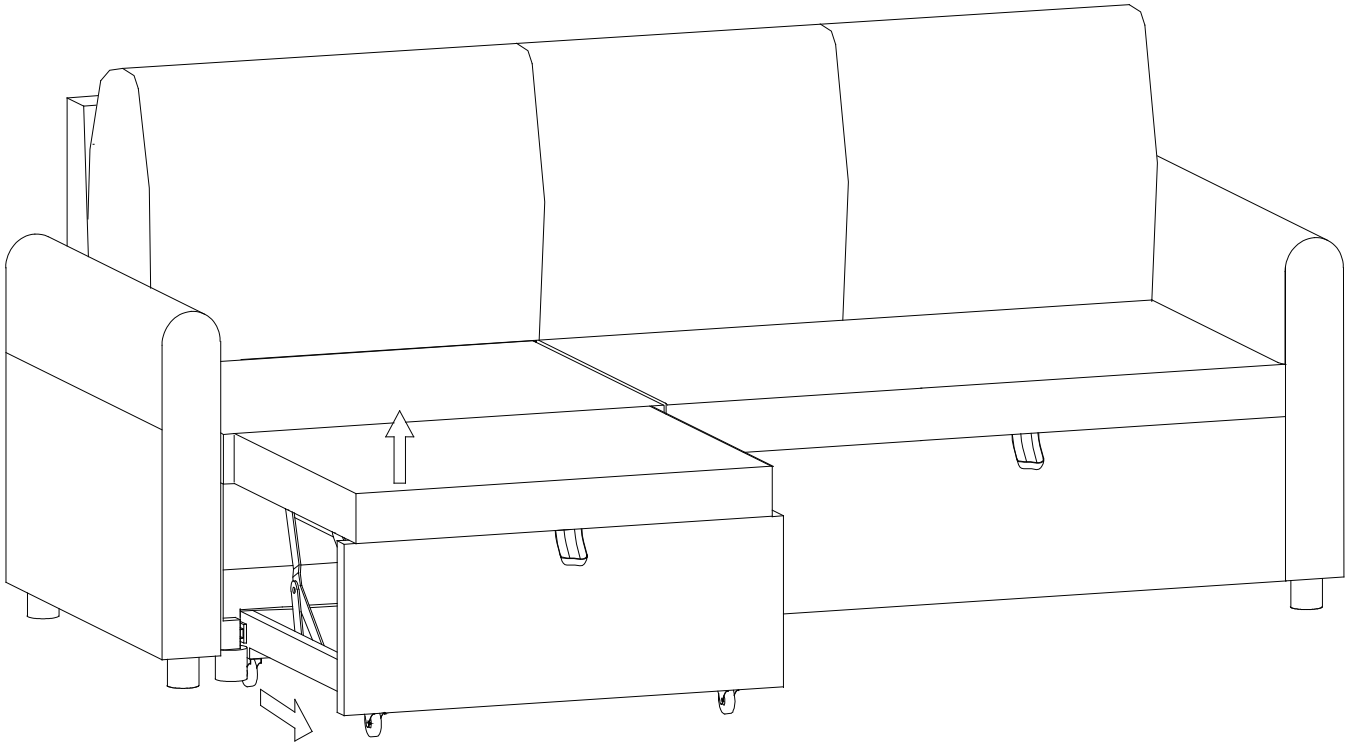

STYLE TWO

