

PART LIST

CODE	QTY	CODE	QTY
A	1	N	1
B	1	O	4
C	1	P	2
D	1		
E	2		
F	1		
G	1		
H	2		
I	1		
J	1		
K	1		
L	1		
M	1		

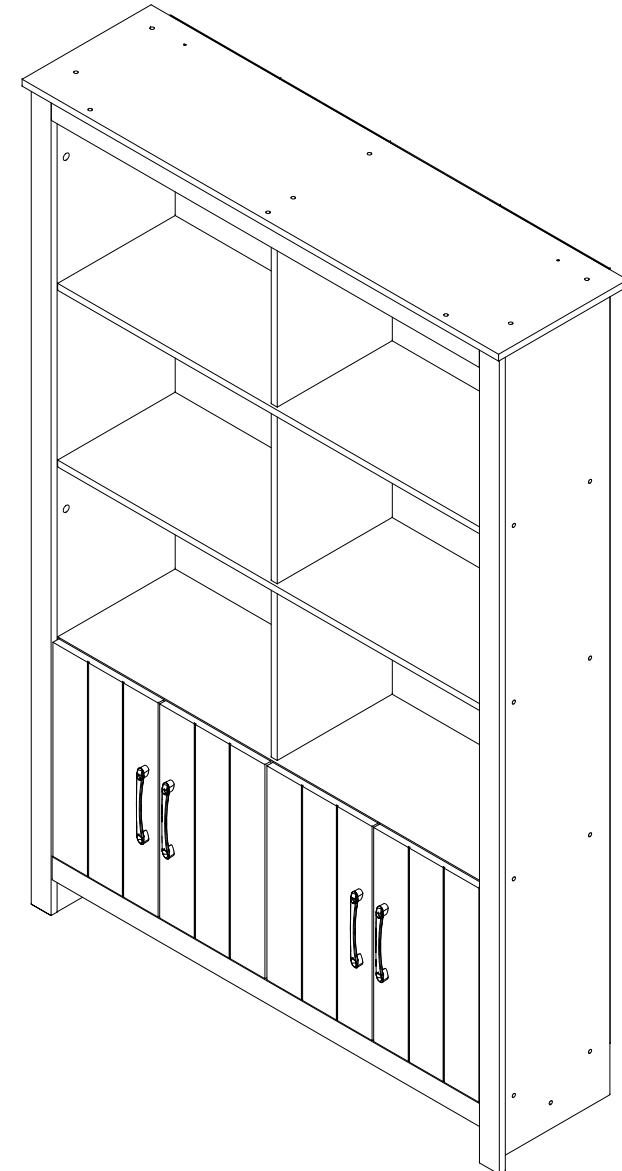
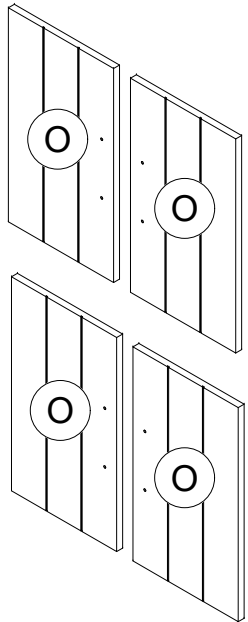
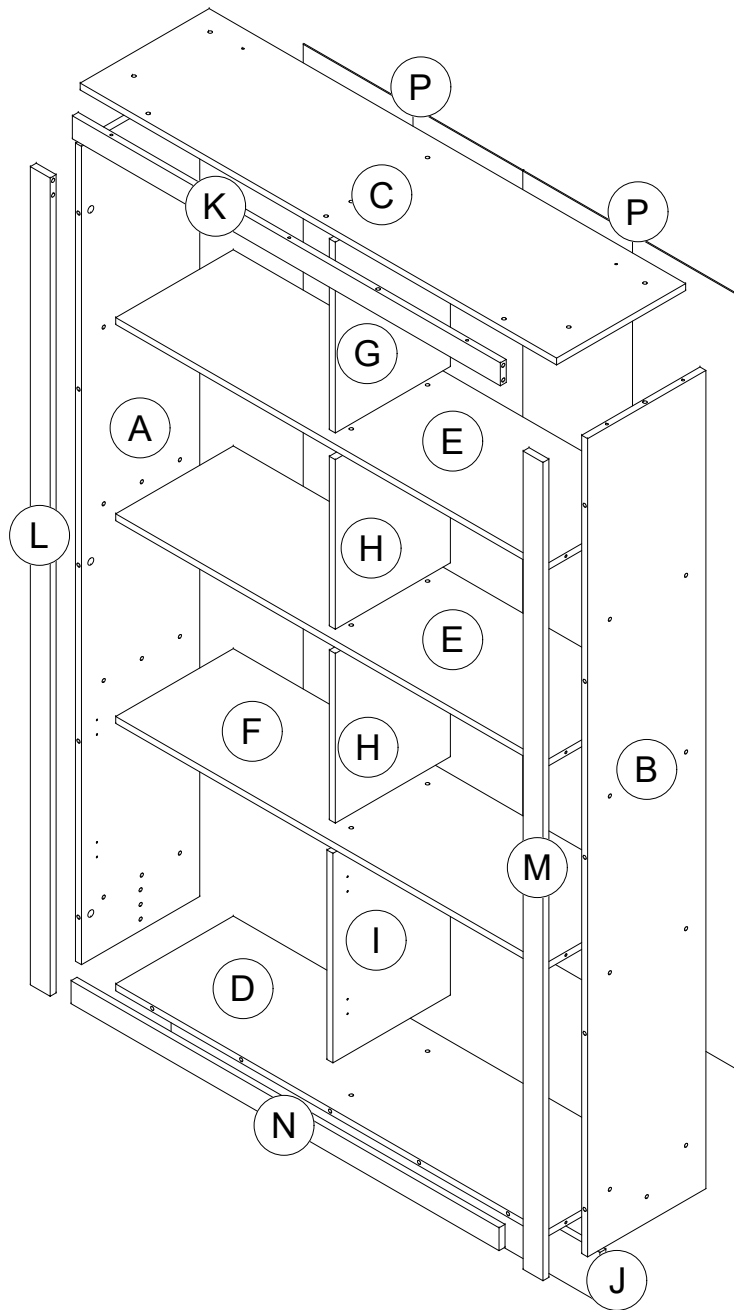

ASSEMBLY INSTRUCTIONS

DO NOT FULLY TIGHTEN ANY BOLTS BEFORE ALL PARTS ARE LOOSELY ASSEMBLED. THE PRODUCT/FITTINGS MAY BE DAMAGED IF OVERTIGHTENED. BEWARE OF CROSS THREADING SCREWS AND BOLTS DURINGS ASSEMBLY. SMALL COMPONENT PARTS COULD CHOKE A CHILD IF SWALLOWED. WE STRONGLY RECOMMEND THAT YOU KEEP CHILDREN AWAY FROM THE WORK AREA.

97015
BOOKCASE

HARDWARE LIST

1		Wood Dowel $\phi 8 \times 30 \text{mm}$	38 pcs
2		Minifix Bolt	9 pcs
3		Minifix Cam	9 pcs
4		Screw $\phi 6.3 \times 50 \text{mm}$	29 pcs
5		Allen Key M4	1 pc
6		Hinges 1/4"	4 pcs
7		PVC Nail With Pin	5 pcs
8		Hinges 7/8"	4 pcs
9		Handle - 128mm	4 pcs
10		Handle Screw $\phi 4 \times 19 \text{mm}$	8 pcs
11		Nail	52 pcs
12		Screw $\phi 3.5 \times 16 \text{mm}$	34 pcs
13		Seal Sticker - 18mm	18 pcs
14		Iron L Bracket	1 pc
AA		1.2 x 15 x 32 x 75mm Mounting L Bracket	2 pcs
BB		Flat Washer $\phi 6$	2 pcs
CC		Tapping Screw #10 x 1/2	2 pcs
DD		Screw $\phi 4 \times 38 \text{mm}$	2 pcs

Minifix Setup :

STEP 4

- STEP 1 UNLOCK
- STEP 2
- STEP 3 LOCK

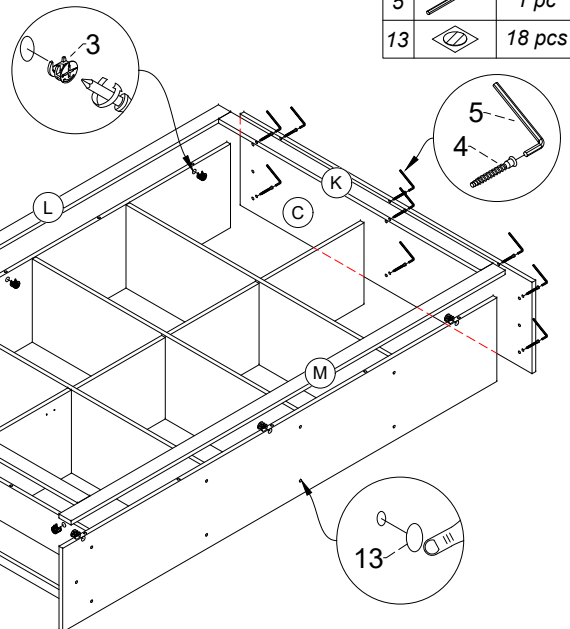

STEP 1

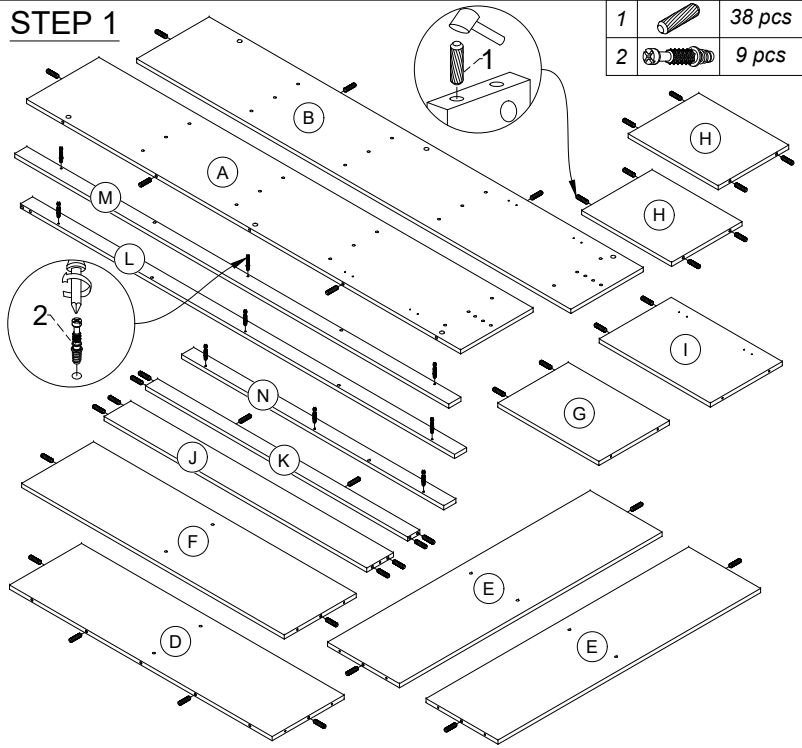

1		38 pcs
2		9 pcs

STEP 2

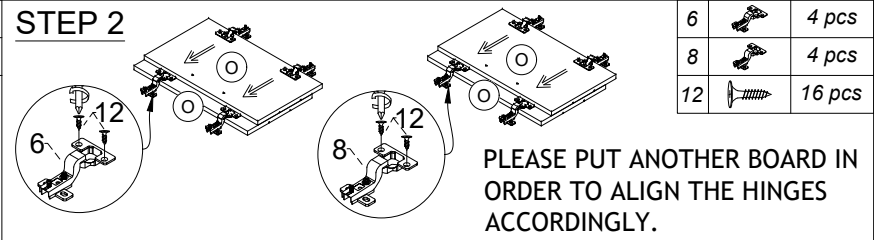

6		4 pcs
8		4 pcs
12		16 pcs

PLEASE PUT ANOTHER BOARD IN ORDER TO ALIGN THE HINGES ACCORDINGLY.

STEP 3

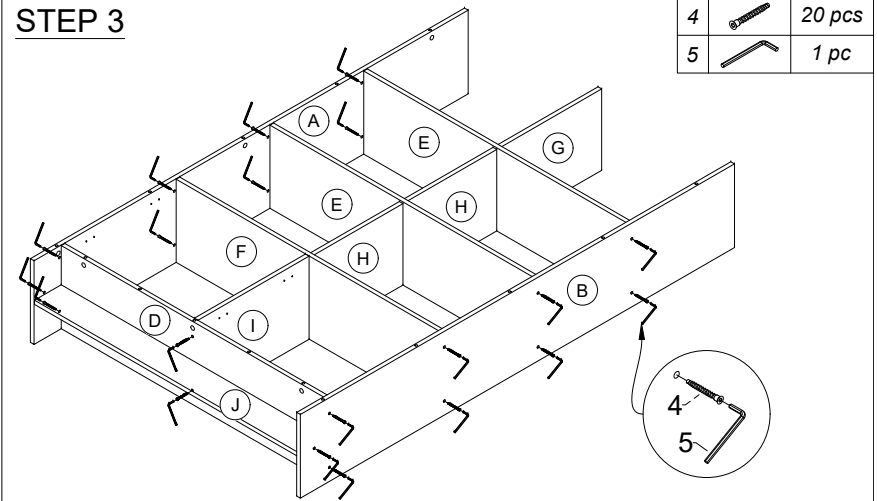

4		20 pcs
5		1 pc

STEP 5

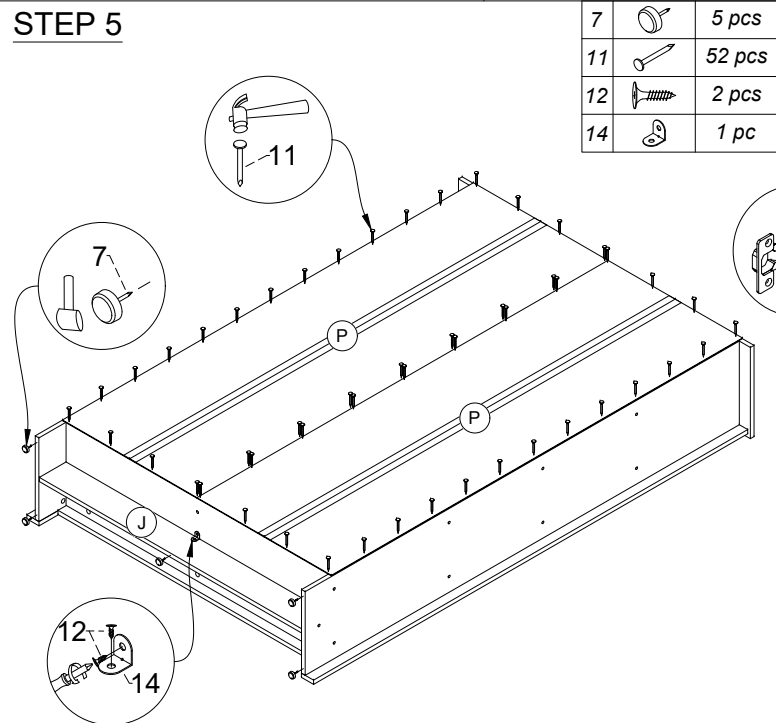

3		9 pcs
4		9 pcs
5		1 pc
13		18 pcs

7		5 pcs
11		52 pcs
12		2 pcs
14		1 pc

STEP 6

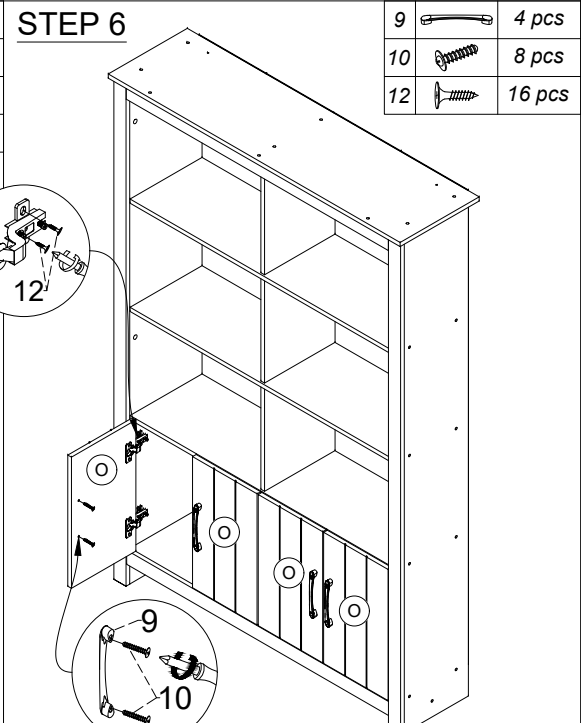

9		4 pcs
10		8 pcs
12		16 pcs

ANTI-TIPPING STEP

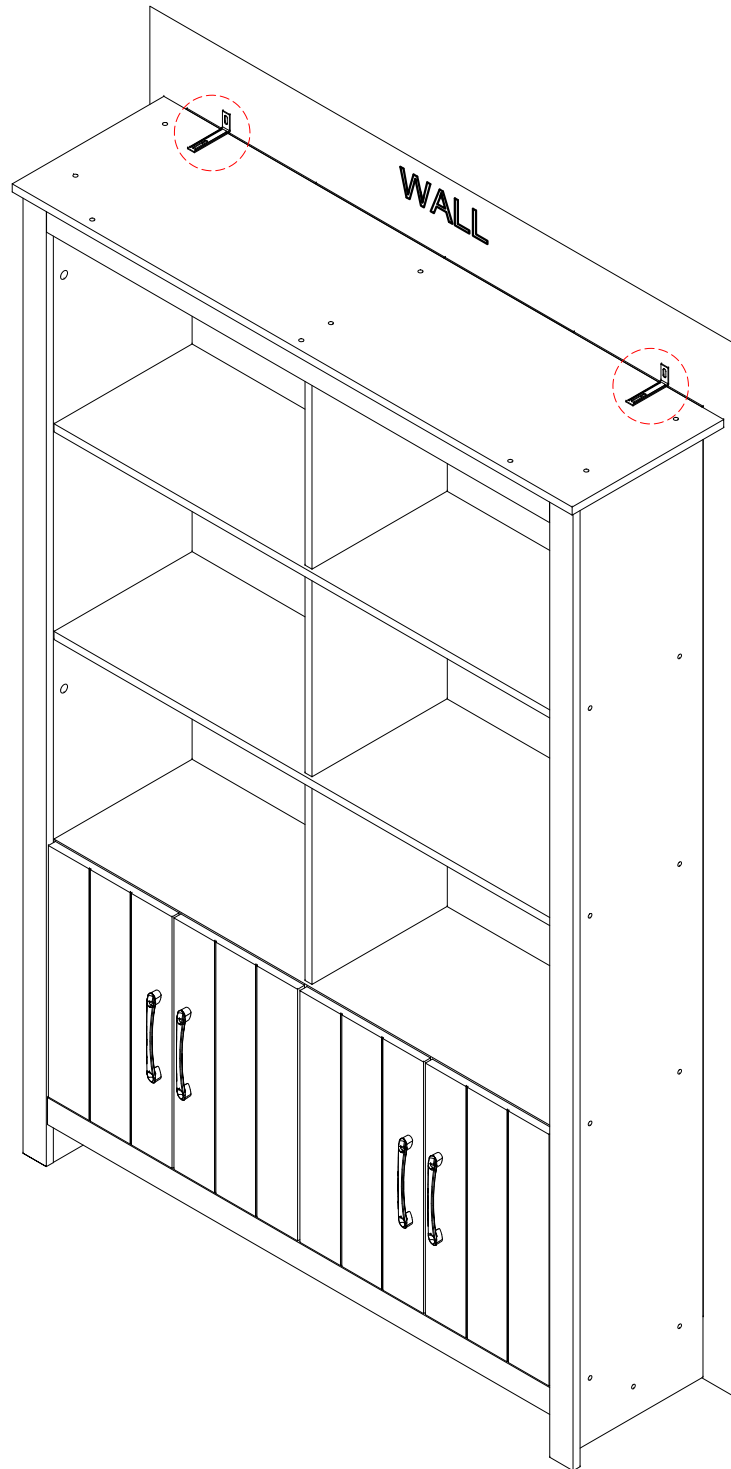

AA		2 pcs
BB		2 pcs
CC		2 pcs
DD		2 pcs

