

PART LIST

CODE	QTY
A	1
B	1
C	1
D	1
E	1
F	1
G	2
H	2
I	1
J	1
K	1
L	1
M	1
N	2
O	1

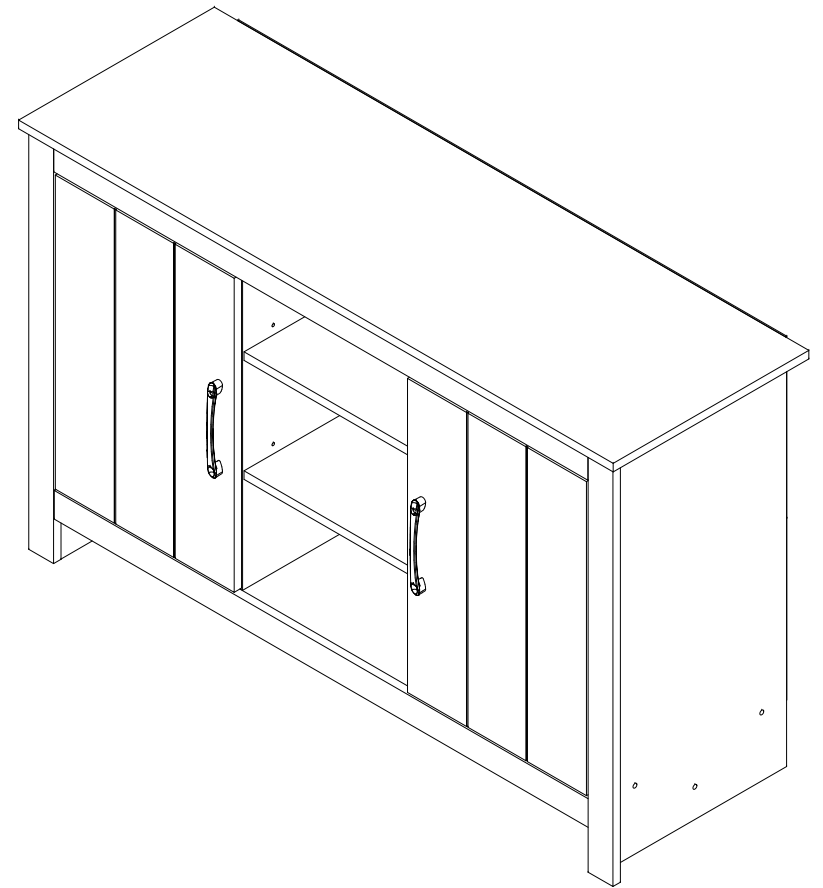
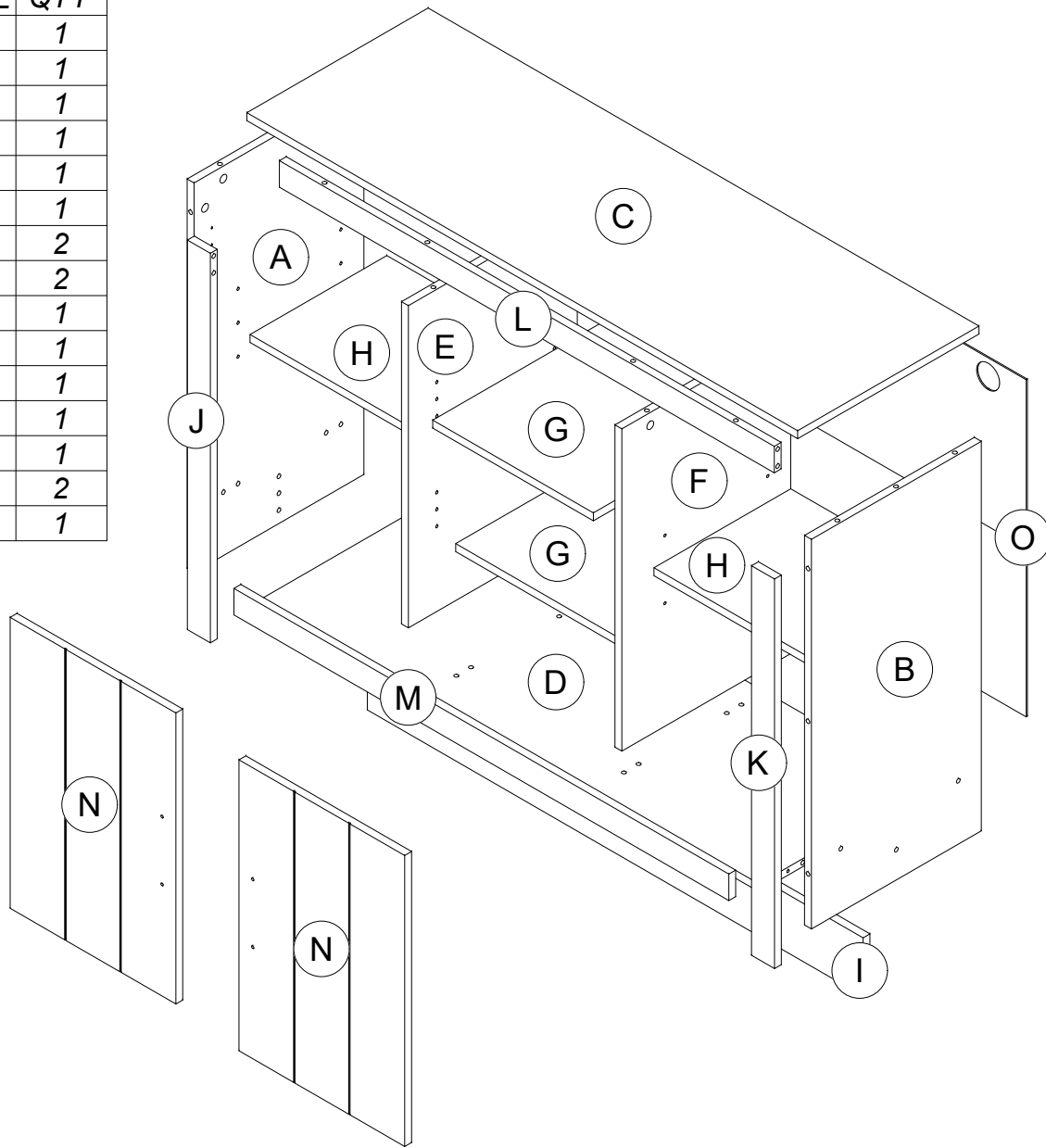

ASSEMBLY INSTRUCTIONS

DO NOT FULLY TIGHTEN ANY BOLTS BEFORE ALL PARTS ARE LOOSELY ASSEMBLED. THE PRODUCT/FITTINGS MAY BE DAMAGED IF OVERTIGHTENED. BEWARE OF CROSS THREADING SCREWS AND BOLTS DURINGS ASSEMBLY. SMALL COMPONENT PARTS COULD CHOKE A CHILD IF SWALLOWED. WE STRONGLY RECOMMEND THAT YOU KEEP CHILDREN AWAY FROM THE WORK AREA.

97016
SIDEBOARD

HARDWARE LIST

1		Minifix Bolt	18 pcs
2		Minifix Cam	18 pcs
3		Wood Dowel $\phi 8 \times 30 \text{mm}$	26 pcs
4		Screw $\phi 3.5 \times 16 \text{mm}$	18 pcs
5		PVC Nail With Pin	5 pcs
6		Hinges 7/8"	4 pcs
7		Handle Screw $\phi 4 \times 19 \text{mm}$	4 pcs
8		Handle - 128mm	2 pcs
9		Shelf Support $\phi 5 \times 16 \text{mm}$	16 pcs
10		Screw $\phi 6.3 \times 50 \text{mm}$	10 pcs
11		Nail	38 pcs
12		Allen Key M4	1 pc
13		Seal Sticker - 18mm	6 pcs
14		Iron L Bracket	1 pc
AA		1.2 x 15 x 32 x 75mm Mounting L Bracket	2 pcs
BB		Flat Washer $\phi 6$	2 pcs
CC		Tapping Screw #10 x 1/2	2 pcs
DD		Screw $\phi 4 \times 38 \text{mm}$	2 pcs

STEP 1

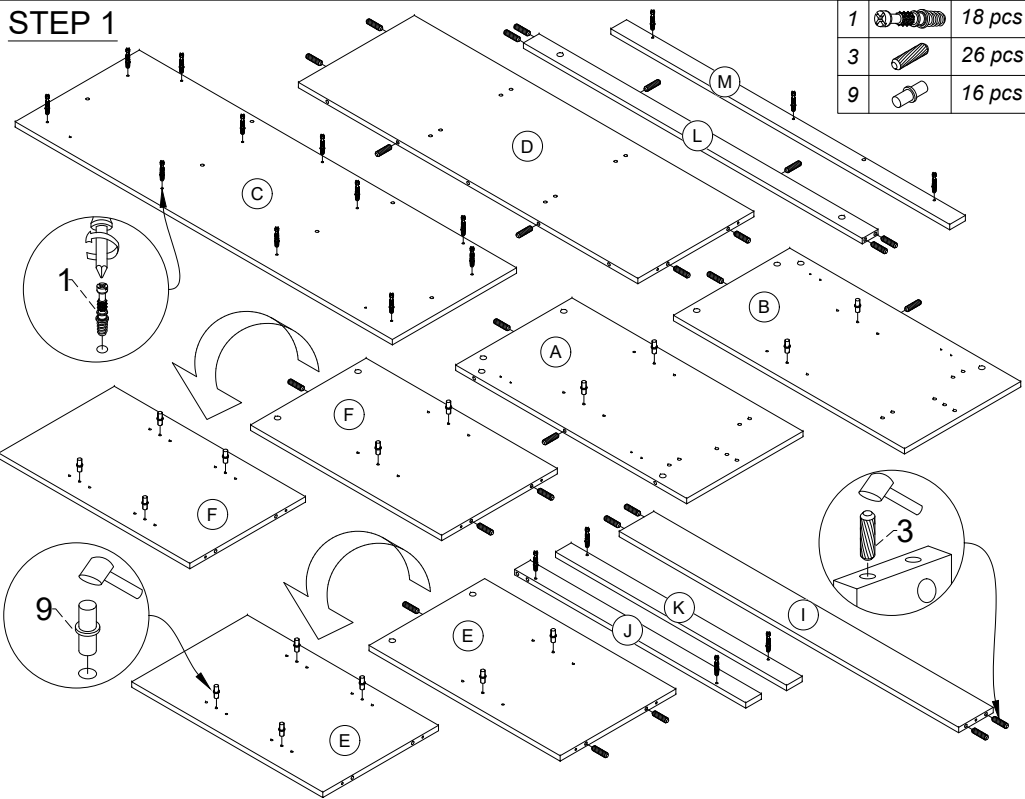

1		18 pcs
3		26 pcs
9		16 pcs

STEP 2

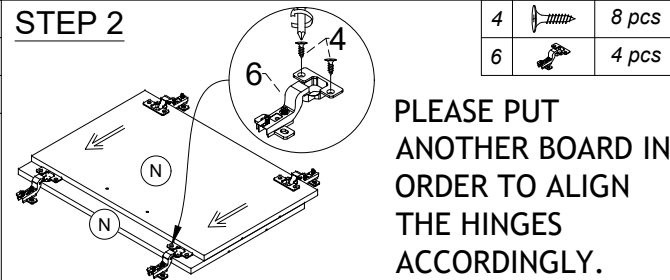

4		8 pcs
6		4 pcs

PLEASE PUT ANOTHER BOARD IN ORDER TO ALIGN THE HINGES ACCORDINGLY.

STEP 3

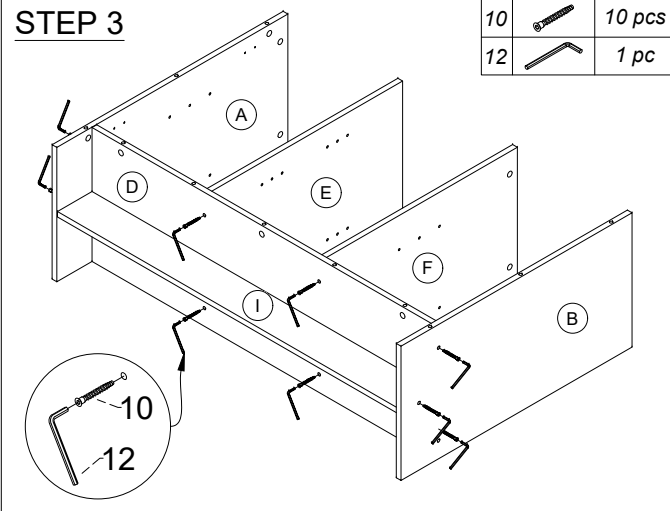

10		10 pcs
12		1 pc

STEP 5

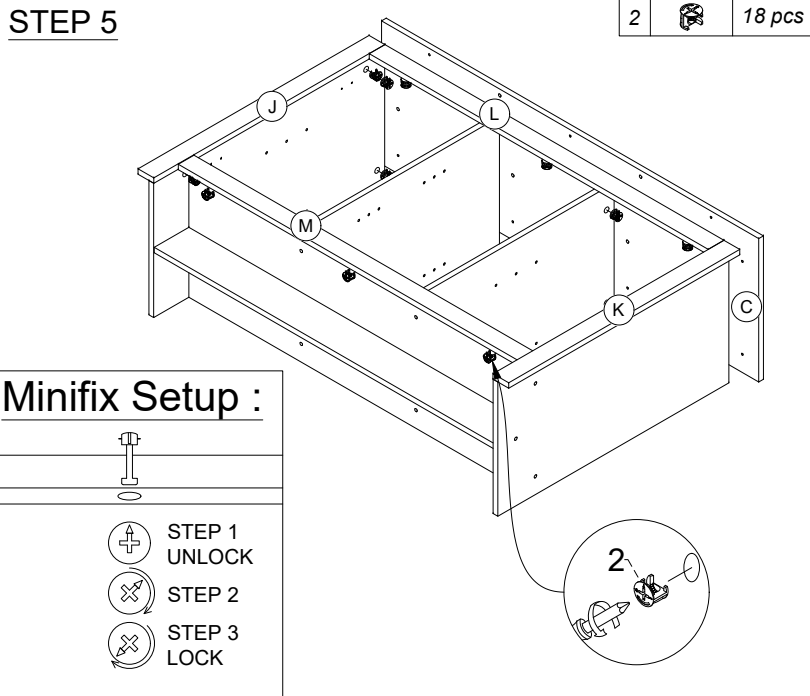

2		18 pcs
---	--	--------

STEP 5

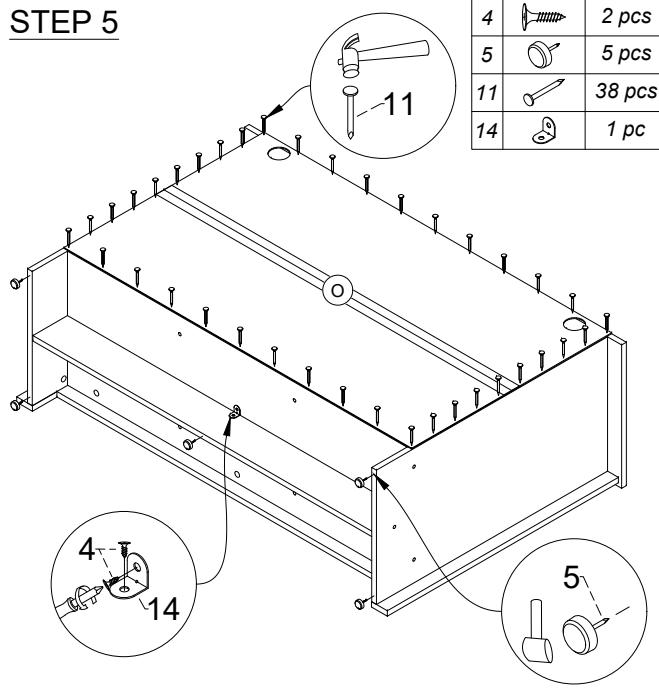

4		2 pcs
5		5 pcs
11		38 pcs
14		1 pc

STEP 6

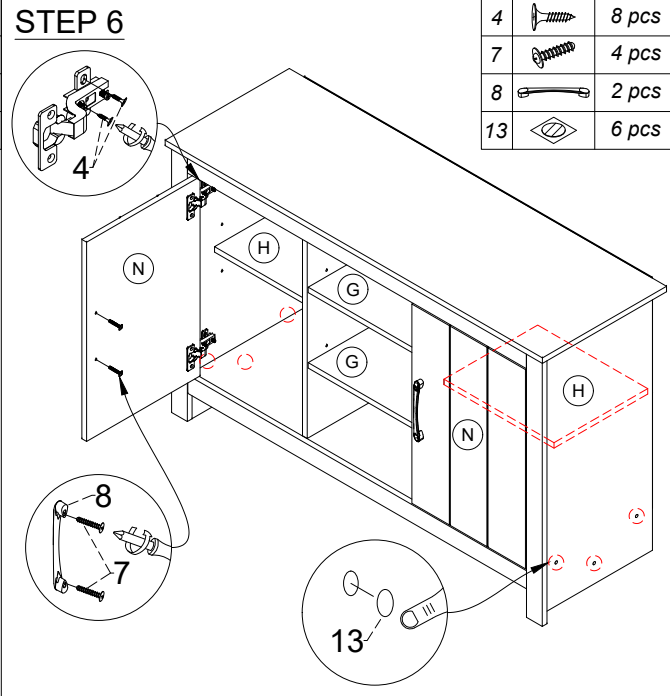

4		8 pcs
7		4 pcs
8		2 pcs
13		6 pcs



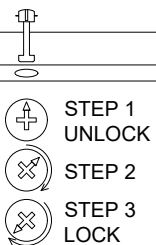

Minifix Setup :

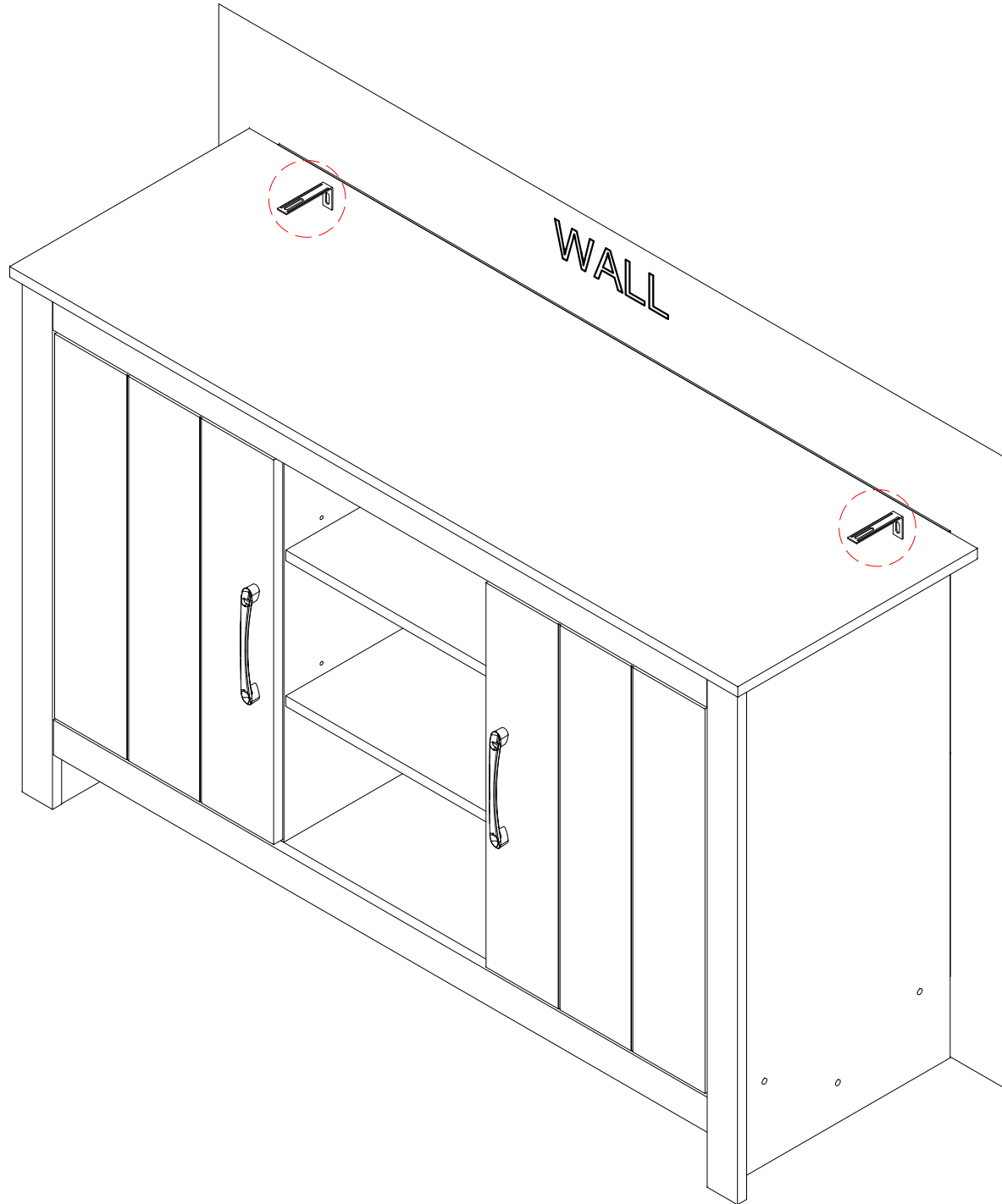

- STEP 1 UNLOCK
- STEP 2
- STEP 3 LOCK

ANTI-TIPPING STEP



AA		2 pcs
BB		2 pcs
CC		2 pcs
DD		2 pcs

