

PART LIST

CODE	QTY
A	1
B	1
C	1
D	1
E	1
F	1
G	1
H	1
I	1
J	1

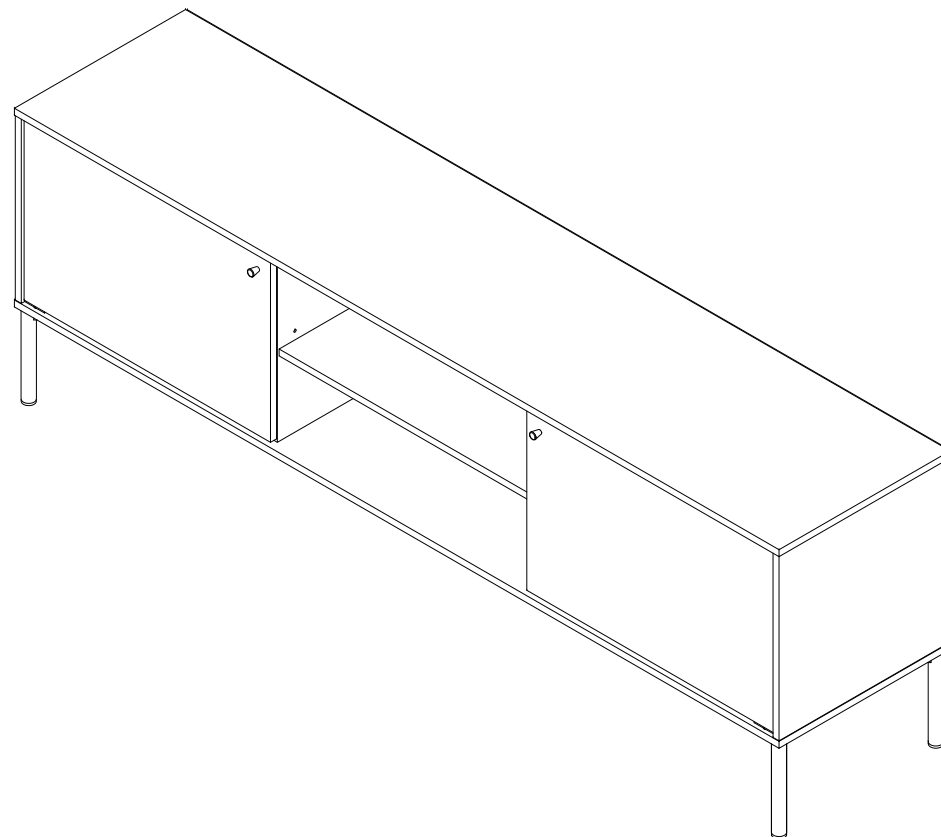
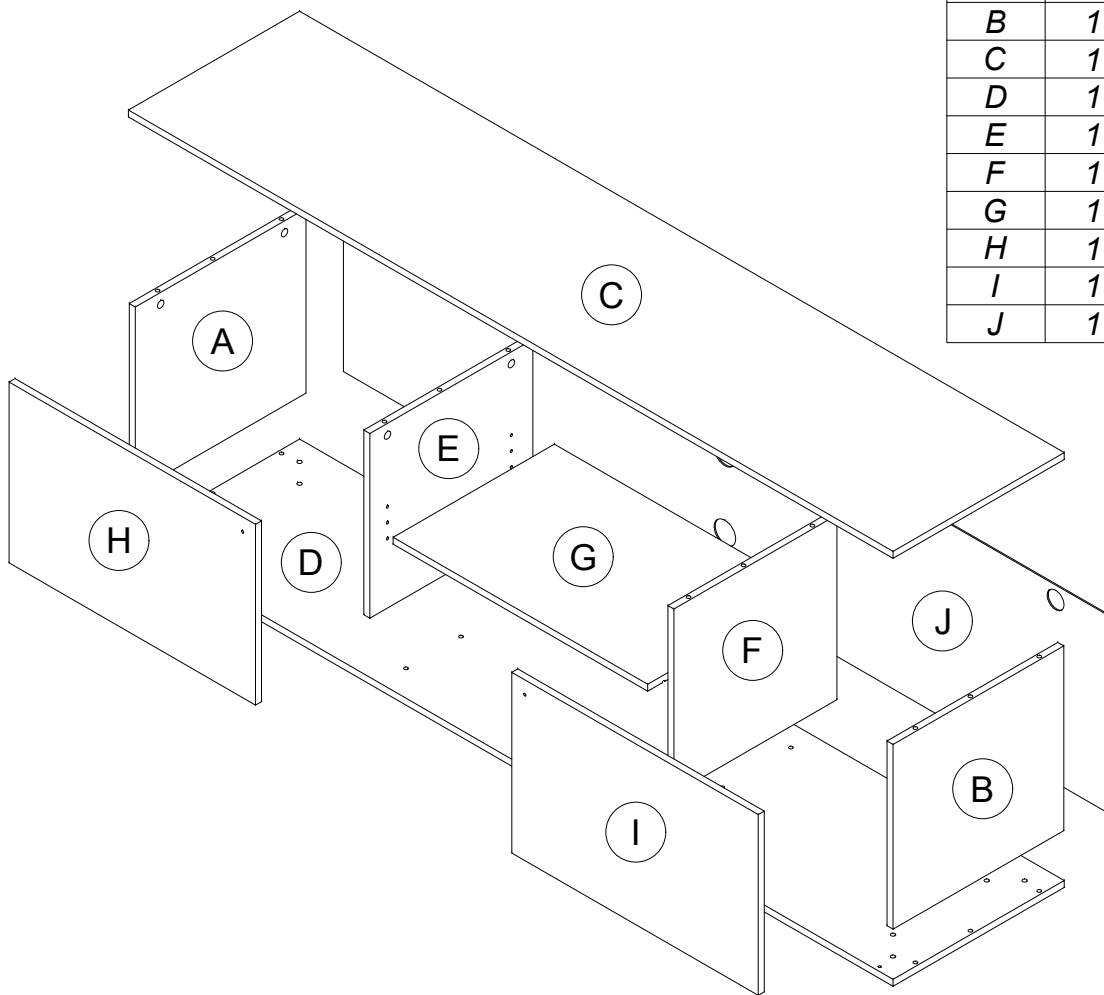

ASSEMBLY INSTRUCTIONS

DO NOT FULLY TIGHTEN ANY BOLTS BEFORE ALL PARTS ARE LOOSELY ASSEMBLED. THE PRODUCT/FITTINGS MAY BE DAMAGED IF OVERTIGHTENED. BEWARE OF CROSS THREADING SCREWS AND BOLTS DURINGS ASSEMBLY. SMALL COMPONENT PARTS COULD CHOKE A CHILD IF SWALLOWED. WE STRONGLY RECOMMEND THAT YOU KEEP CHILDREN AWAY FROM THE WORK AREA.

97035

2 DOOR TV CABINET

HARDWARE LIST

1		Wood Dowel $\phi 8 \times 30 \text{mm}$	8 pcs
2		Unitar Screw $\phi 6.3 \times 40 \text{mm}$	8 pcs
3		Minifix Bolt	8 pcs
4		Minifix Cam	8 pcs
5		Allen Key M4	2 pcs
6		Shelf Support $\phi 5 \times 16 \text{mm}$	4 pcs
7		Metal Leg - 190mm	4 pcs
8		Magnet	2 pcs
9		Magnet Plate	2 pcs
10		JCN Nut M6 x 12mm	8 pcs
11		Flat Washer $\phi 6 \times 19 \text{mm}$	8 pcs
12		Adjust Screw $\phi 6 \times 23 \text{mm}$	1 pc
13		Metal Leg - 180mm	1 pc
14		Tapping Screw #10 x 1/2	4 pcs
15		Screw $\phi 3.5 \times 14 \text{mm}$	12 pcs
16		Knob Handle	2 pcs
17		Handle Screw $\phi 4 \times 18 \text{mm}$	2 pcs
18		MT Door Stopper	4 pcs
19		Nail	28 pcs
20		Screw $\phi 6 \times 30 \text{mm}$	8 pcs
21		Spring Washer M6	8 pcs
AA		1.2 x 15 x 32 x 75mm Mounting L Bracket	2 pcs
BB		Flat Washer $\phi 6$	2 pcs
CC		Tapping Screw #10 x 1/2	2 pcs
DD		Screw $\phi 4 \times 38 \text{mm}$	2 pcs

Minifix Setup :

STEP 1 UNLOCK
 STEP 2 LOCK
 STEP 3 UNLOCK

STEP 1

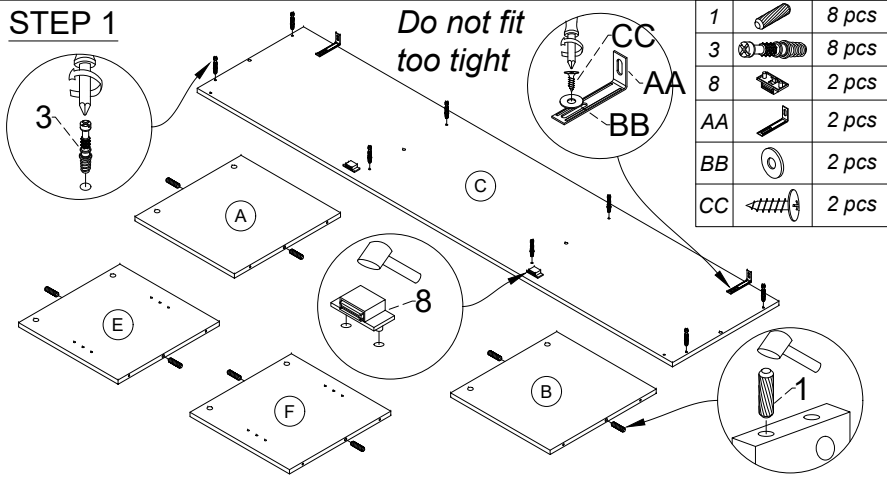

STEP 2

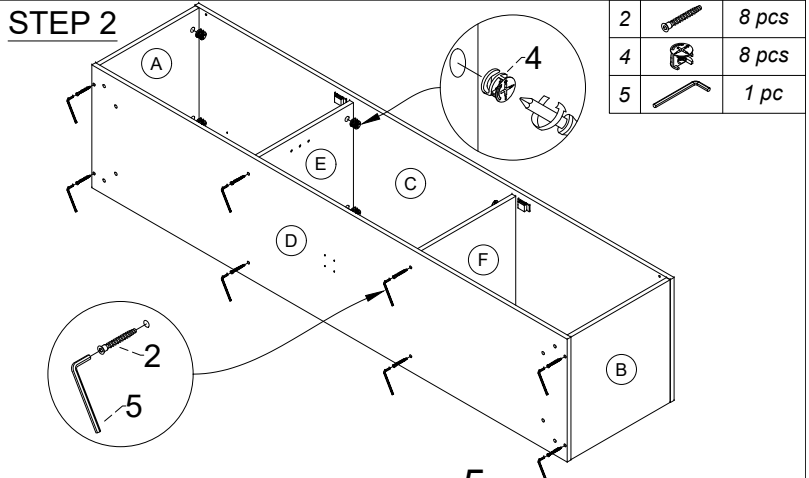

STEP 3

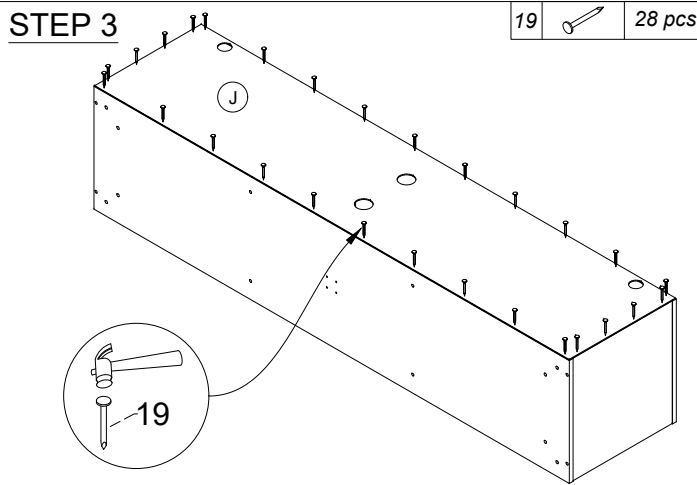

STEP 4

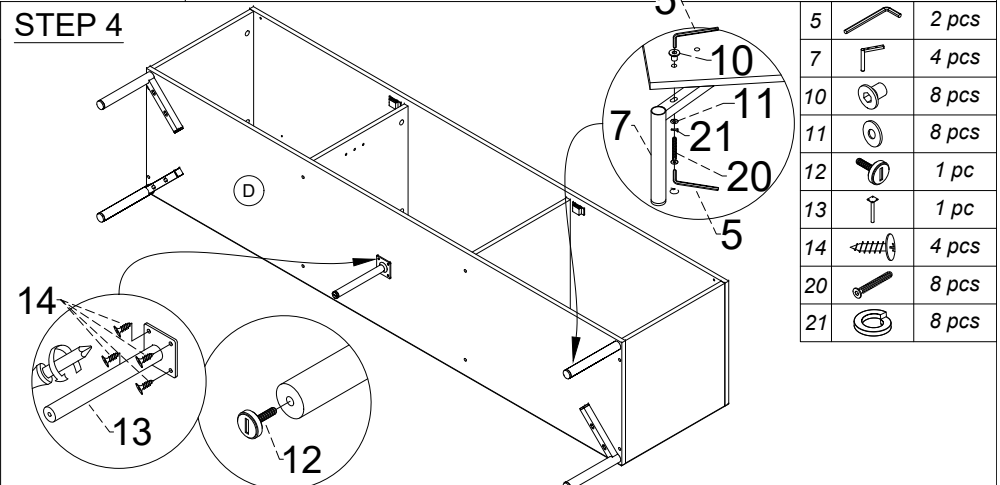

STEP 5

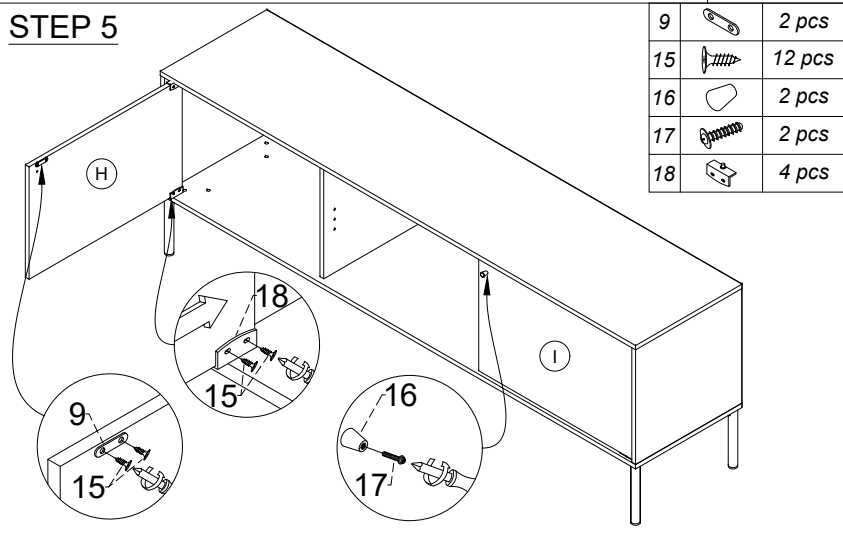

STEP 6

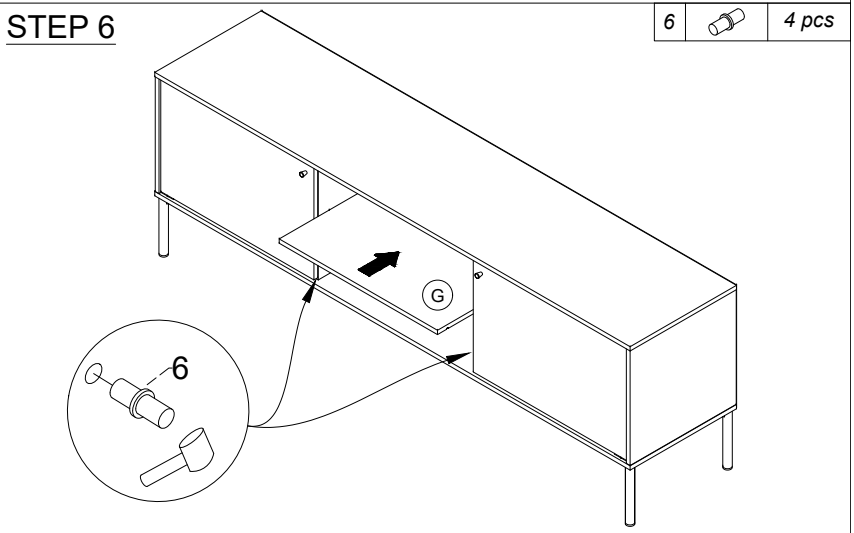

ANTI-TIPPING STEP

DD  2 pcs

